

- Measures dc or average value of pulse currents
- Usable as digital current integrator, digital charge integrator, or digital electrometer
- Wide dynamic range
- Input protected to  $\pm 1000$  V (0.01  $\mu$ F) or  $\pm 2000$  V (0.001  $\mu$ F)

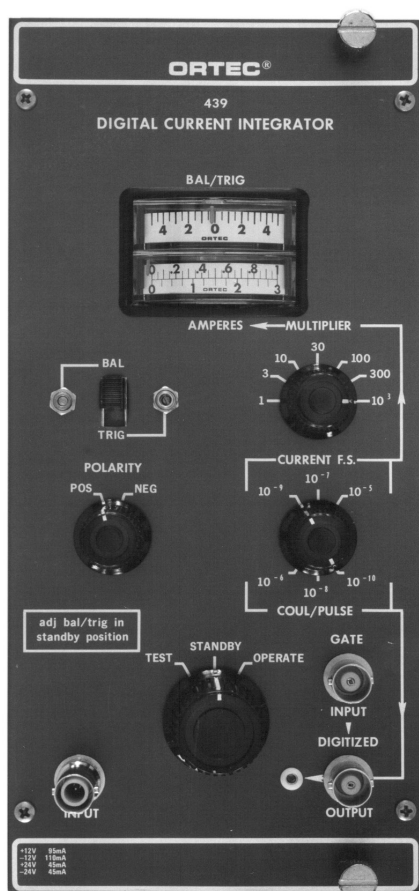

The ORTEC Model 439 Digital Current Integrator was designed to accurately measure DC currents or the average value of pulse currents such as produced by accelerator beams. It digitizes the input current by producing an output pulse for specific values of input charge. A front-panel switch permit the selection of three different amounts of charge ( $10^{-10}$ ,  $10^{-8}$  or  $10^{-6}$  coulomb) required to produce an output pulse. The instrument has a digitizing rate from 0 to 10 kHz to provide wide dynamic range on each setting and high-resolution readout without meter interpolation.

The Model 439, when combined with a preset counter, forms a digital charge integrator. When it is combined with a counter and timer, a digital electrometer is obtained.

A front-panel meter is provided to read the input current. Full-scale analog outputs of 1 mA, 100 mV, and 10 mV are provided on rear-panel binding posts. Full-scale readings for the front-panel meter and the analog outputs can be selected in 15 steps from  $1 \times 10^{-9}$  to  $1 \times 10^{-2}$  A. The input is protected from damage by application of a large input charge.

Front- and rear-panel BNC connectors are provided for the application of a Gate signal to inhibit the digitized output. This Gate may be used to remotely control the Model 439 or it may be used to inhibit the digitized output with a multichannel analyzer dead time output signal.

## Specifications

### PERFORMANCE

**LEAKAGE IMPEDANCE FROM INPUT TO GROUND**  $> 1 \times 10^{10} \Omega$ .

**INPUT LEAKAGE CURRENT**  $< 1 \times 10^{-12}$  A.

**TEMPERATURE INSTABILITY**  $\leq \pm 0.05\%/^{\circ}\text{C}$ , 0 to  $50^{\circ}\text{C}$ .

**DIGITIZED OUTPUT INACCURACY** Readings from 100 nA to 10 mA DC,  $\leq \pm 0.2\%$ ; for 50 nA, typically  $\pm 0.3\%$  (count rate on  $10^{-10}$  coulomb/pulse range limited to 1 kHz).

**DIGITIZED REPRODUCIBILITY** 0.01%.

**ANALOG ACCURACY** Front-panel meter 2%; rear-panel binding posts 1.5%.

### CONTROLS AND INDICATOR

**MULTIPLIER** Front-panel switch determines the multiplier to be applied to the Current F.S. reading to produce a full-scale deflection on the Ampere Meter.

**CURRENT F.S. AND COUL/PULSE** Front-panel switch, controls amount of charge that must be injected at the input to obtain a digital output pulse (low, medium, and high selection for each).

**TEST-OPERATE** Front-panel 3-position switch controls the function of the Model 439:

**Test** Internal test current is provided to produce an output of  $\sim 1000$  Hz on all coulomb/pulse ranges.

**Standby** Grounds the input of the Model 439 preventing application of transients to the input amplifier.

**Operate** Position in which the Model 439 will normally be used; connects the input amplifier to the front- and rear-panel SHV input connectors.

**POLARITY** Front-panel switch selects the polarity, Pos or Neg, of the input current to be measured.

**BAL/TRIG** Front-panel switch used in conjunction with Bal/Trig Meter and Test/Operate switch balances and adjusts the Model 439 input amplifier.

**OFFSET/CURRENT** Rear-panel potentiometer adjusts the input offset current over a range of  $\sim \pm 10$  pA.

### INPUTS

**SIGNAL INPUT** Through front- and rear-panel SHV connectors.

**Impedance** Virtually ground with maximum excursion of  $< \pm 5$  mV.

**Current Polarity** Positive or negative.

**Current Range**  $1 \times 10^{-9}$  to  $1 \times 10^{-2}$  A.

**GATE** Signal normally enabled in absence of an input or when the DC value is nominally +6 V; front- and rear-panel BNC connectors.

**To Enable Output** +3 V or greater.

**To Inhibit Output** +1.5 V or less (e.g., can be shorted to ground by a relay).

**Maximum Input** +25 V, -10 V.

**Duty Cycle Limitation** None, DC-coupled.

**Input Impedance**  $> 1000 \Omega$ ; driving source must be capable of sinking 1 mA of current from a positive source.

### OUTPUTS

**DIGITIZED** Signal +5 V, 500 ns wide; 0 to 10 kHz; front- and rear-panel BNC connectors.

### ANALOG

**Front-Panel Meter** 0-1 and 0-3 scales serving all multiplier ranges. There are 15 full-scale ranges.

**Rear-Panel Binding Posts** 0 to 1 mA full scale; 0 to 100 mV full scale; 0 to 10 mV full scale. There are 15 full-scale ranges.

### ELECTRICAL AND MECHANICAL

**POWER REQUIRED** The Model 439 derives its power from a standard NIM bin/power supply, such as the ORTEC Model 4001A/4002A. Required power is +24 V, 45 mA; -24 V, 45 mA; +12 V, 95 mA; -12 V, 110 mA.

### WEIGHT

**Net** 1.7 kg (3.75 lb).

**Shipping** 3.06 kg (6.75 lb).

**DIMENSIONS** NIM-standard triple-width module 10.28 X 22.13 cm (4.05 X 8.714 in.) front panel per DOE/ER-0457T.

### Related Equipment

The Model 439 may be combined with an ORTEC preset counter to form a digital charge integrator or with a counter and timer to form a digital electrometer.

### Ordering Information

Model	Description
439	Digital Current Integrator

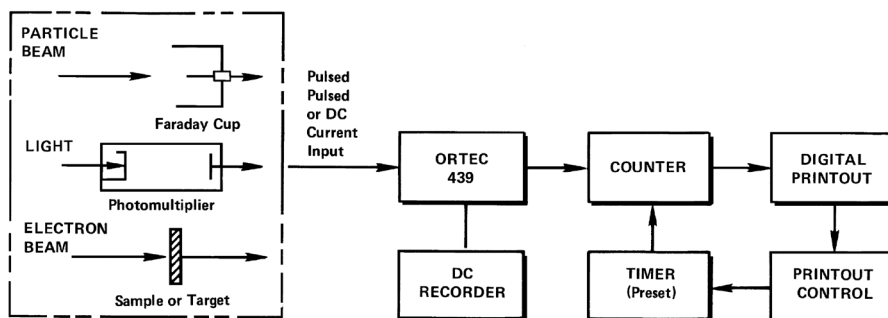

Typical Current Digitizing System

