

- General-purpose amplifier for energy spectroscopy with all types of detectors
- Built-in pile-up rejector and gated BLR with automatic thresholds for excellent performance at high counting rates
- Unipolar and bipolar outputs
- Active filter networks with wide range of time constants
- Wide gain range



The ORTEC Model 572A Amplifier is ideally suited for use with germanium detectors, silicon charged-particle detectors, proportional counters, scintillation counters, and pulsed ion chambers. It includes an automatic gated baseline restorer and a built-in pile-up rejector to provide exceptionally stable performance over a very wide dynamic range. System resolution is nearly independent of input counting rate (Fig. 1).

The gated baseline restorer (BLR) includes a discriminator that operates the sensing circuits that normally establish the baseline reference for the MCA. Performance of the spectrometer depends on the precision of the setting of the BLR threshold. The Model 572A offers the convenience of an automatic threshold control, which typically gives as good or better results than those the most experienced operator could achieve manually. The gate logic generates a Busy signal that can be used for dead-time correction.

The active filter networks permit the Model 572A to generate very symmetrical unipolar outputs with optimum signal-to-noise ratios over a wide range of time constants. The instrument also provides a bipolar output for timing and gating applications.

Any DC drift in an amplifier output causes spectrum broadening. The excellent DC stability of the Model 572A eliminates spectrum broadening caused by DC drift and ensures that the high-resolution capability of germanium detectors is realized.

Specifications

PERFORMANCE

GAIN RANGE Continuously adjustable from 1 to 1500.

PULSE SHAPE Semi-Gaussian on all ranges with peaking time equal to 2.2τ and pulse width at 0.1% level equal to 2.9 times the peaking time.

INTEGRAL NONLINEARITY For 2- μ s shaping time, $< \pm 0.05\%$.

NOISE Typically $< 5 \mu\text{V}$ for unipolar output referred to the input, using 2- μ s shaping and Coarse Gain ≥ 100 .

TEMPERATURE INSTABILITY

Gain $\leq \pm 0.0075\%/^{\circ}\text{C}$, 0 to 50°C .

DC Level $\leq \pm 50 \mu\text{V}/^{\circ}\text{C}$, 0 to 50°C .

BIPOLAR CROSSOVER WALK $\leq \pm 3$ ns at 0.5- μ s shaping, 50:1 dynamic range when used in conjunction with an ORTEC Model 552 Single-Channel Analyzer.

OVERLOAD RECOVERY Recovers to within 2% of rated output from X300 overload in 2.5 nonoverloaded pulse widths using maximum gain for unipolar output. Same recovery from X1000 overload for bipolar.

SPECTRUM BROADENING Typically $< 16\%$ FWHM for a ^{60}Co 1.33-MeV gamma line at 85% of full scale for an incoming count rate of 1 to 100,000 counts/s. Unipolar output, 2- μ s shaping.

SPECTRUM SHIFT Peak position shifts typically $< 0.024\%$ for a ^{60}Co 1.33-MeV gamma line at 85% of full scale measured from 1 to 100,000 counts/s at the unipolar output, 2- μ s shaping.

CONTROLS

FINE GAIN 10-turn precision potentiometer with graduated dial for continuously variable direct-reading gain factor of X0.5 to X1.5.

COARSE GAIN 6-position switch selects feedback resistors for gain factors of 20, 50, 100, 200, 500, and 1k. Jumper on the printed wiring board (PWB) selects X0.1 attenuation.

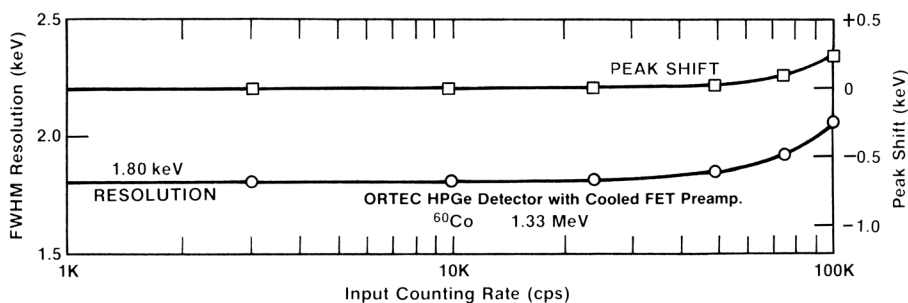

Fig. 1. Typical Resolution and Baseline Stability vs Counting Rate for the Model 572A in a Gamma Spectroscopy System.

572A Amplifier

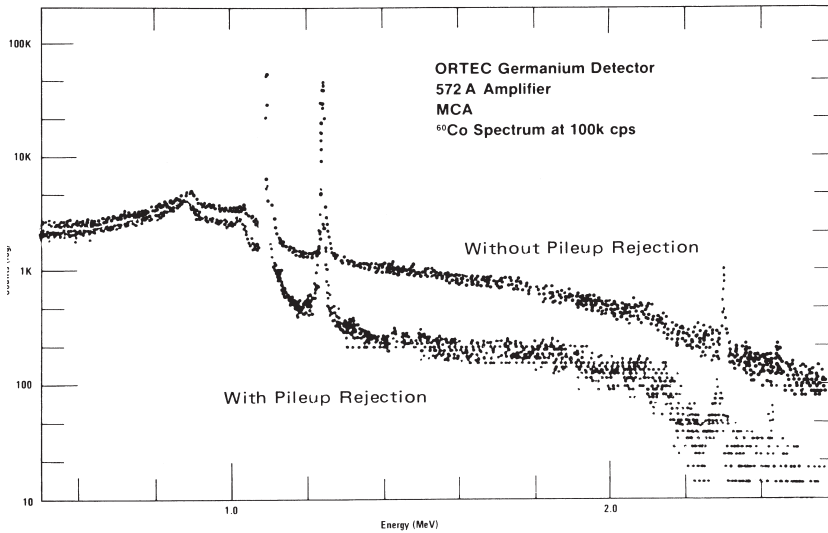

Fig. 2. Background Reduction Obtained from Pile-Up Rejection.

Pile-Up Rejector

The pile-up rejection circuit incorporated into the Model 572A generates an inspection period immediately following every signal equal to the duration of the Busy output. If a second event were to occur within this inspection interval, an inhibit signal, INH Output, would be generated to gate-off the MCA and thus discard the distorted amplifier output. Figure 2 shows the background reduction that takes place in a gamma-ray spectrum as pile-up rejection is used. Figure 3 illustrates the timing relationship between the amplifier input, output, and pile-up rejector logic signals.

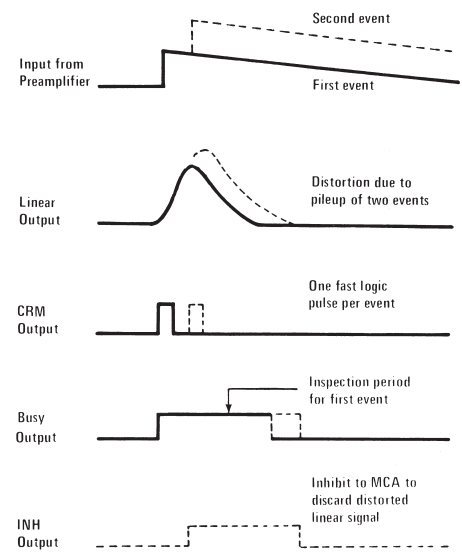
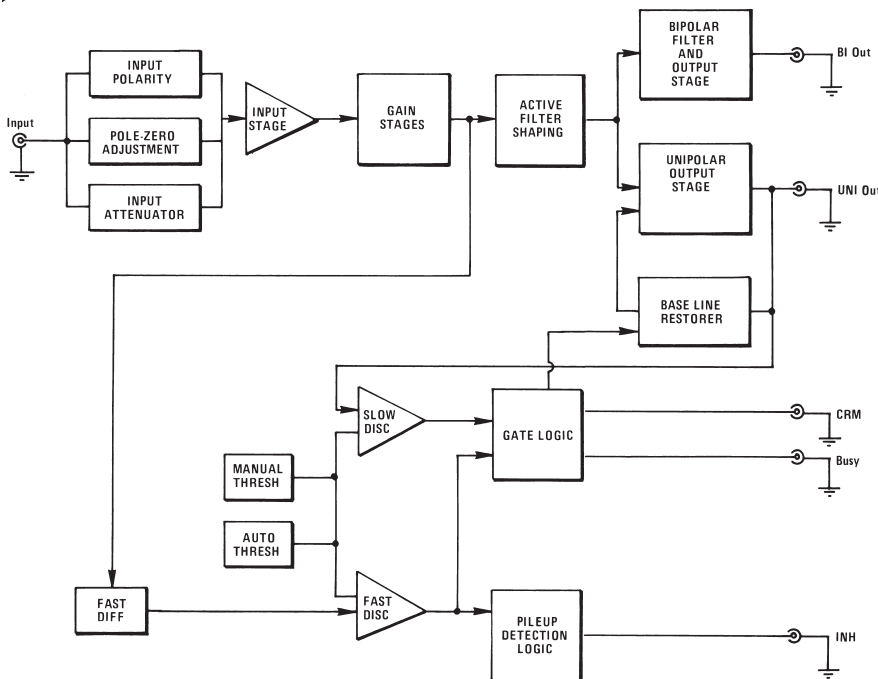

Fig. 3. Amplifier and Pile-Up Rejector Signals.



572A Amplifier

SHAPING TIME 6-position switch selects time constants for active pulse-shaping filter network from 0.5, 1, 2, 3, 6, and 10 μ s.

INPUT Locking toggle switch selects either Pos or Neg input pulse polarity.

PZ ADJ Screwdriver adjustable potentiometer to set the pole-zero cancellation to compensate input decay times from 40 μ s to ∞ .

BLR 3-position locking toggle switch selects the source of control for the gated baseline restorer discriminator threshold from:

Auto The BLR threshold is automatically set to an optimum level, as a function of the signal noise, by an internal circuit.

PZ Adj The BLR threshold is determined by the threshold potentiometer. The BLR time constant is also greatly increased to facilitate PZ adjustment; this position may give the lowest noise for count rates under 5000 counts/s and/or longer shaping times.

Threshold The BLR threshold is manually set by the threshold potentiometer.

DC Screwdriver adjustable potentiometer to set the unipolar output DC level; range ± 100 mV.

INPUTS

INPUT BNC front- and rear-panel connectors accept either positive or negative pulses with rise time of 10 to 650 ns and decay times of 40 μ s to ∞ ; $Z_{in} \cong 1000 \Omega$ DC-coupled; linear maximum 10 V; absolute maximum 20 V.

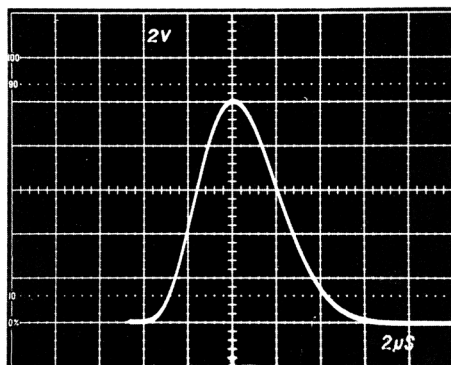

Unipolar Output

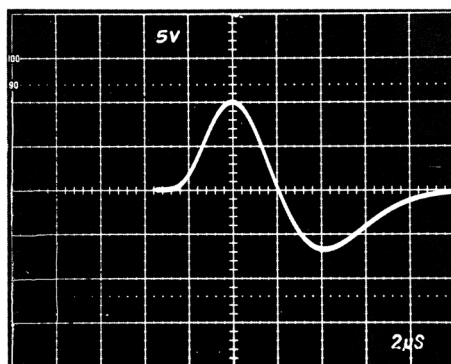

Bipolar Output

OUTPUTS

UNI Front-panel BNC connector with $Z_o < 1 \Omega$ and rear-panel connector with $Z_o = 93 \Omega$, short-circuit proof; with full scale linear range of +10 V; active filter shaped; DC-restored, DC level adjustable to ± 100 mV.

BI Front-panel BNC connector with $Z_o < 1 \Omega$ and rear-panel connector with $Z_o = 93 \Omega$, short circuit proof; prompt output with positive lobe leading and linear range of ± 10 V; active filter shaped.

CRM Rear-panel BNC connector with $Z_o < 10 \Omega$ provides a nominally +5 V, 300 ns logic pulse every time the input signal exceeds the baseline restorer discriminator threshold.

INH Rear-panel BNC connector with $Z_o < 10 \Omega$ provides a nominally +5 V logic pulse (width equal to 6X shaping time) when the internal pile-up rejection logic detects a distortion of the input signal due to pile-up.

BUSY Rear-panel BNC connector with $Z_o < 10 \Omega$ provides a +5 V logic pulse for the duration that the input pulse exceeds the baseline restorer discriminator.

PREAMP POWER Rear-panel standard ORTEC power connector, Amphenol 17-10090, mates with captive and noncaptive power cords on all ORTEC preamplifiers.

ELECTRICAL AND MECHANICAL

POWER REQUIRED +12 V, 85 mA; -12 V, 50 mA; +24 V, 100 mA; -24 V, 105 mA.

WEIGHT

Net 1.5 kg (3.3 lb).

Shipping 3.1 kg (7.0 lb).

DIMENSIONS Standard single-width nIM module 3.43 X 22.13 cm (1.35 X 8.714 in.) per DOE/ER-0457T.

Ordering Information

To order, specify:

Model	Description
572A	Amplifier

572A Amplifier



www.ortec-online.com

Tel. (865) 482-4411 ortec.info@ametek.com

801 South Illinois Avenue, Oak Ridge, TN 37830 U.S.A.

Visit Our Website For International Office Locations

Specifications subject to change
24-0919