

- For fast timing with germanium and other semiconductor detectors
- Fast <8-ns rise time
- Independent integration and differentiation
- Gated baseline restorer
- Pole-zero cancellation
- 50-Ω delay cable clipping
- Voltage gain X0.9 to X500
- Output drives to ±5 V on a 50-Ω load

The ORTEC Model 579 Wideband Fast-Filter Amplifier with gated baseline restorer (Fig. 1) enhances fast-timing measurements by improving the noise-to-slope ratio and providing ultra-high count rate spectroscopy capability.

A fast rise time (<8 ns), high output drive (±5 V into 50 Ω), and wide voltage gain range (X0.9–X500) make the Model 579 useful for many timing applications, including those utilizing low-gain photomultiplier tubes. The Model 579 is particularly suited for use with ORTEC Constant-Fraction Discriminators such as Models 583 or 935 in timing applications with high-purity germanium (HPGe) or silicon charged-particle detectors (Figs. 2 and 9 and Tables 1 and 2). Excellent DC and gain stability (±50 μV/°C and ±0.05%/°C, respectively) eliminate the need for a DC level adjustment. A Busy LED and Busy Output are included to aid in BLR adjustment and system interfacing.

In addition, the wideband gated baseline restorer and pole-zero cancellation network permit ultra-high output counting rates. A wide variety of pulse filtering is available for improved signal processing. The Model 579 combines continuously variable gain, independently selectable integration and differentiation time constants (Out, 10, 20, 50, 100, 200, and 500 ns), and cable clipping capability (external cable delay), making this versatile unit an important asset for sophisticated time and energy spectroscopy.

Specifications

PERFORMANCE

INPUT SIGNAL AMPLITUDE RANGE ±1 V AC, ±5 V AC with X5 internal attenuator; ±35 V DC; input impedance 100 Ω, AC-coupled; 50 Ω optional.

OUTPUT AMPLITUDE RANGE 0 to ±5 V linear into a 50-Ω load.

RISE TIME <8 ns with Integrate and Differentiate Out, or $\approx 2.2 \tau_i$ for other integrate settings and Differentiate Out.

OVERSHOOT <10% with Integrate Out, or <2% for any selected integration.

NOISE For maximum gain, rms noise referred to the input is <10 μV (typically 5 μV), with $\tau_i = \tau_D = 200$ ns, measured with an HP3400A true rms voltmeter. Wideband (200 MHz) noise for $\tau_i = \tau_D =$ Out is <50 μV (typically 40 μV).

INTEGRAL NONLINEARITY $\leq \pm 1\%$ (typically 0.5%) over ±5 V range into 50-Ω load.

TEMPERATURE INSTABILITY

DC Level $\leq \pm 50 \mu\text{V}/^\circ\text{C}$ referred to the output; factory-set within ±5 mV.

Gain $\leq \pm 0.05\%/^\circ\text{C}$.

OPERATING TEMPERATURE RANGE 0 to 50°C.

CONTROLS

COARSE GAIN Front-panel 6-position switch to select X15, X25, X50, X125, X250, and X500 gain factor. When internal X5 attenuator is used, the coarse gain factors represent X3, X5, X10, X25, X50, and X100, respectively. A continuously variable voltage gain of X0.9 to X500 can be obtained. (Gain reduced by factor of two when cable clip is used.)

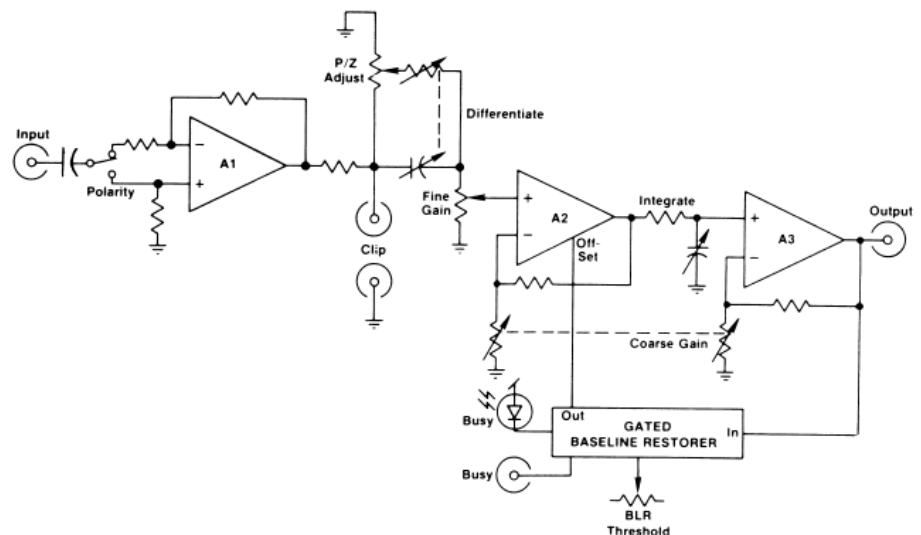
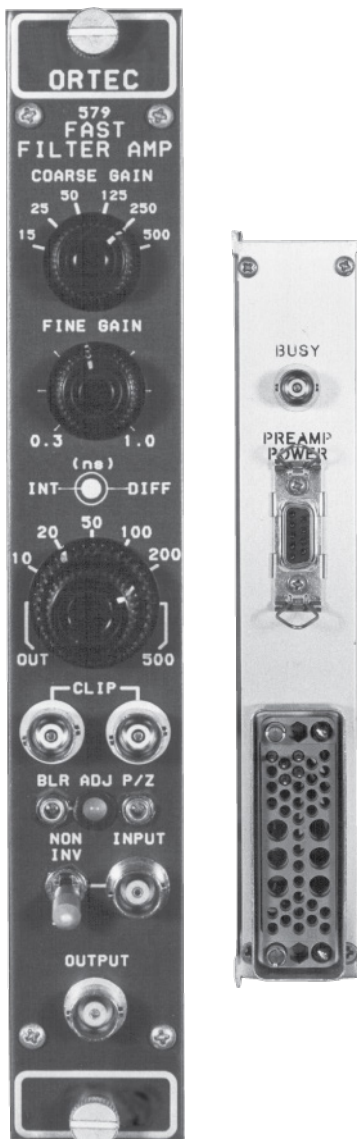

Fig. 1. Block Diagram of the Model 579 Fast-Filter Amplifier.

579

Fast-Filter Amplifier

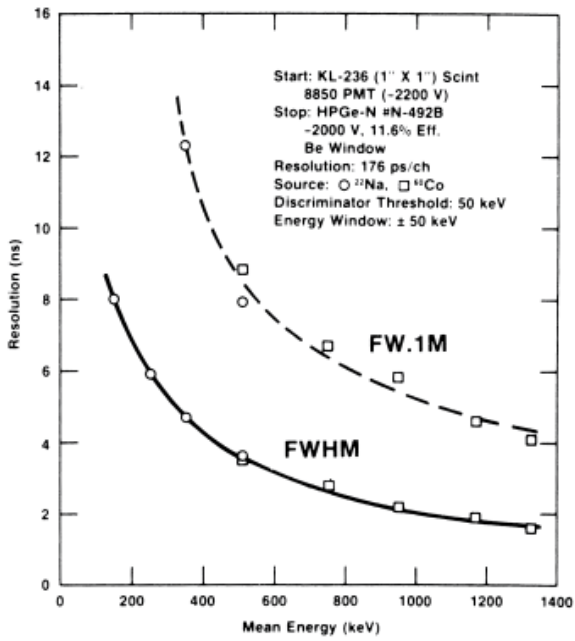

Fig. 2. Timing Resolution FWHM and FW.1M as a Function of Energy an Energy Window of \pm 50 keV.

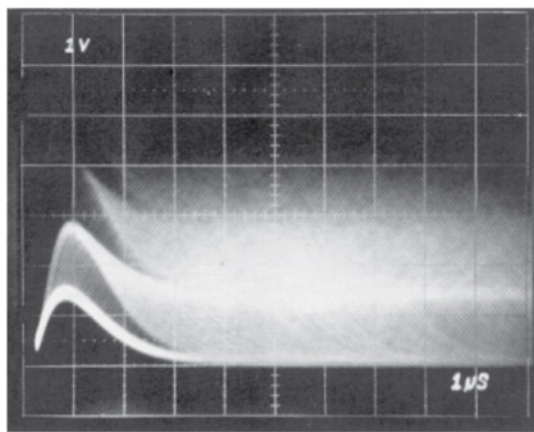

Fig. 5. Example of Model 579 Ultra-High Output Count Rate Capability. Input Signal from a BNC Random Pulse Generator at Approximately 1 Million Counts per Second. Fast-Filter Amplifier $\tau_i = \tau_D = 500$ ns.

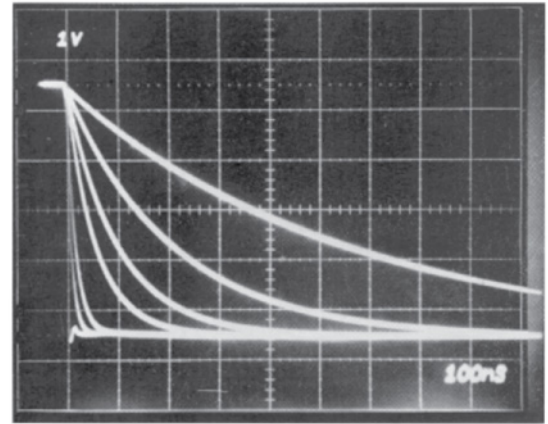

Fig. 3. Model 579 Output Signals for $\tau_D =$ Out and $\tau_i =$ Out, 10, 20, 50, 100, 200, and 500 ns.

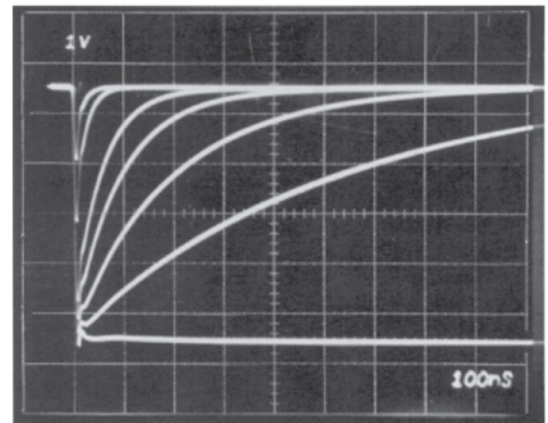

Fig. 4. Model 579 Output Signals for $\tau_i =$ Out and $\tau_D =$ Out, 10, 20, 50, 100, 200, and 500 ns.

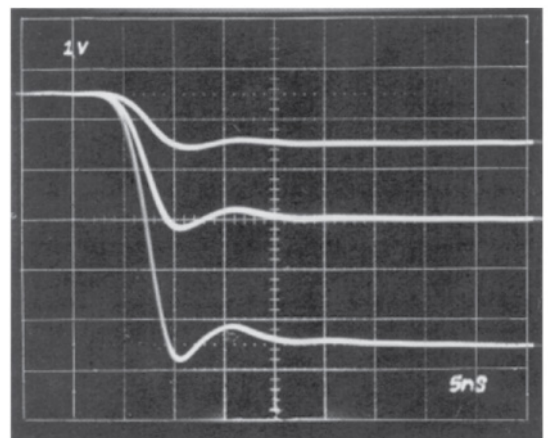

Fig. 6. Model 579 Output Signals for $\tau_i = \tau_D =$ Out at 1, 2, and 5 V.

Fast-Filter Amplifier

FINE GAIN Front-panel single-turn potentiometer, continuously adjustable from 0.3 to 1.0.

P/Z Front-panel screwdriver adjustable potentiometer to adjust pole-zero cancellation for decay time constants from 25 μ s to ∞ .

DIFF Front-panel 7-position switch selects a differentiation time constant to control the decay time of the pulse. Decay time $\approx 2.2 \tau_D$ with $\tau_i = \text{Out}$. The τ_D settings include Out, 10, 20, 50, 100, 200, and 500 ns.

INT Front-panel 7-position switch selects an integration time constant to control the rise time of the output pulse. The rise time is $\approx 2.2 \tau_i$ with $\tau_D = \text{Out}$. The τ_i settings include Out, 10, 20, 50, 100, 200, and 500 ns. Rise time in the Out position is < 5 ns, equivalent to a $\tau_i < 2.3$ ns.

INV/NONINV Front-panel locking toggle switch selects inversion or noninversion of the input signal.

BLR ADJ Front-panel screwdriver adjustment to set the Gated BLR threshold from ± 50 mV to ± 500 mV referred to the output.

BLR GATED/UNGATED Printed wiring board (PWB) jumper selects gated or ungated BLR operation. Factory set in gated position.

BLR LED This feature enables the user to quickly adjust the BLR threshold setting near the noise peak. Front-panel LED indicates an output amplitude has exceeded the BLR threshold. The BLR LED can be used as a visual indicator of the output counting rate.

COUNT RATE High/Low PCB jumper selects minimum BLR dead time of typically 400 ns in high position and typically 1 μ s in low position. Factory-set in low position.

ATTENUATOR PWB jumper select to pass with unity Gain or Attenuate by a factor of 5. Jumper select B to C and A to F will pass with unity Gain. Jumper select C to D and E to F will attenuate by a factor of 5. Factory-set at unity Gain.

INPUTS

INPUT Front-panel BNC accepts input signals of either polarity. ± 1.0 V AC or ± 5.0 V AC with X5 attenuator. Maximum DC voltage ± 35 V. Input impedance 100 Ω (to match preamplifiers), AC-coupled.

CLIP Two front-panel BNC connectors to provide delay line clipping of the input pulse. Cable impedance must be 50 Ω . Delay line clip is 2X the cable propagation delay. Gain is reduced by factor of 2 when using cable clip.

OUTPUTS

OUTPUT Front-panel BNC connector furnishes the amplified and shaped signal through $Z_o < 1 \Omega$. Amplitude 0 to ± 5 V into 50 Ω ; rise time and decay time constants controlled by the integrate and differentiate filter settings.

BUSY Rear-panel BNC furnishes NIM-standard positive logic signal during the BLR busy time.

PREAMP POWER Rear-panel standard ORTEC power connector, Amphenol type 17-80090-15.

ELECTRICAL AND MECHANICAL

POWER REQUIRED +24 V, 80 mA; -24 V, 80 mA; 12 V, 160 mA; -12 V, 140 mA.

WEIGHT

Net 1.5 kg (3.3 lb).

Shipping 3.1 kg (7.0 lb).

DIMENSIONS Standard single-width NIM module 3.43 X 22.13 cm (1.35 X 8.714 in.) per DOE/ER-0457T.

Ordering Information

Model	Description
579	Fast-Filter Amplifier

Table 1. Timing Resolution in ns as a Function of Energy for an Energy Window of ± 50 keV.

Detector System	Detector Type	Efficiency (%)	Constant-Fraction Delay (ns)	Measure	Timing Resolution (ns)								
					Mean Energy (keV) Using ^{22}Na				Mean Energy (keV) Using ^{60}Co				
					150	250	350	511	511	750	950	1170	1330
1	HPGe-P	17.7	26	FWHM FW.1M	9.2	6.9 41.2	5.6 12.8	4.2 9.0	4.2 9.9	3.7 8.6	2.8 7.6	2.6 6.0	2.2 5.8
	HPGe-P	28.0	34	FWHM FW.1M	11.3	8.8 55.8	7.7 27.1	5.6 12.8	6.2 13.4	5.7 12.3	4.0 11.8	3.6 9.8	3.4 9.0
3	HPGe-P	11.0	24	FWHM FW.1M	9.2	6.7 45.3	5.8 22.2	4.0 9.9	3.9 10.2	3.0 8.4	2.6 7.5	2.0 5.6	1.7 5.1
4	HPGe-N	11.6	23	FWHM FW.1M	8.0 78	5.9 27.5	4.7 12.3	3.6 7.9	3.5 8.8	2.8 6.7	2.1 5.8	1.9 4.6	1.6 4.1
5	HPGe-N	19.8	23	FWHM FW.1M	12.5 84	8.6 33	7.0 18.1	4.5 10.2	4.9 11.8	3.7 8.6	3.1 7.7	2.2 5.5	2.0 4.9
6	HPGe-N	16.4	24	FWHM FW.1M	8.6 77.3	6.7 22.5	5.6 16.2	4.1 9.7	4.2 10.7	3.1 8.1	2.7 7.4	2.3 5.5	2.0 5.1

Table 2. Timing Resolution for Large Germanium Detectors.

Detector	Efficiency	FWHM Energy Resolution (keV)	Constant Fraction Delay (ns)	Timing Resolution (ns)			
				E > 100 keV		E = 1332 \pm 50 keV	
				FWHM	FW.1M	FWHM	FW.1M
N30526A	73%	2.05	34	5.4	19.4	3.7	8.8
P20171	81%	1.97	34	5.5	27.0	4.7	13.8
N20366A	88%	2.34	36	5.8	21.2	5.5	16.4

579
Fast-Filter Amplifier



www.ortec-online.com
Tel. (865) 482-4411 ortec.info@ametek.com
801 South Illinois Avenue, Oak Ridge, TN 37830 U.S.A.
Visit Our Website For International Office Locations

Specifications subject to change
24-01211