

A gamma ray interacting with a scintillator produces a pulse of light that is converted to an electric pulse by a photomultiplier tube (PMT). The PMT consists of a photocathode, a focusing electrode, and 10 or more dynodes that multiply the number of electrons striking at each dynode. A chain of resistors typically located in a plug-in tube base assembly biases the anode and dynodes. Complete assemblies including the scintillator and PMT are available.

The properties of a scintillation material required to produce a good detector are transparency, availability in large size, and large light output proportional to gamma-ray energy. Few materials have good properties for detectors. Thallium-activated sodium iodide [NaI(Tl)] and cesium iodide [CsI(Tl)] crystals are commonly used, as well as a wide variety of plastics. CsI(Tl) and plastics have much faster light decay times than NaI(Tl) and are primarily used for timing applications.

The high Z of iodine in NaI(Tl) crystals result in high efficiency for gamma-ray detection. Resolution for a 3-inch diameter by 3-inch length crystal is typically about 7% for ¹³⁷Cs and slightly worse for larger sizes. The light decay time constant for a NaI(Tl) crystal is about 0.23 μ s. Typical charge-sensitive preamplifiers translate this into an output voltage pulse with a rise-time of about 0.5 μ s. Fast coincidence measurements cannot achieve the very short resolving times that are possible for plastic scintillators, especially at low gamma-ray energies.

The Model 905 Series offers various sizes of NaI(Tl) detectors. These detectors are assembled and supplied to ORTEC by several companies that specialize in the manufacture of NaI(Tl) detectors.

Typical, total counting efficiencies given as a percentage for a 1- μ Ci ¹³⁷Cs source centered at a distance of 10-cm:

905-1 (1" x 1"): 0.17 @0.5 MeV and 0.09 @2.0 MeV

905-3 (2" x 2"): 0.75 @0.5 MeV and 0.45 @2.0 MeV

905-4 (3" x 3"): 2.00 @0.5 MeV and 1.30 @2.0 MeV

NOTE: Special sizes and configurations such as Wells, Thin-Window X-Ray, Thyroid Counters, and Large Slabs are available on special order.



905 NaI Detectors with digiBASE attached.

905 Series NaI(Tl) Scintillation Detectors

905-1 NaI Scintillation Detector, 1- x 1-in. crystal, 2-in. tube

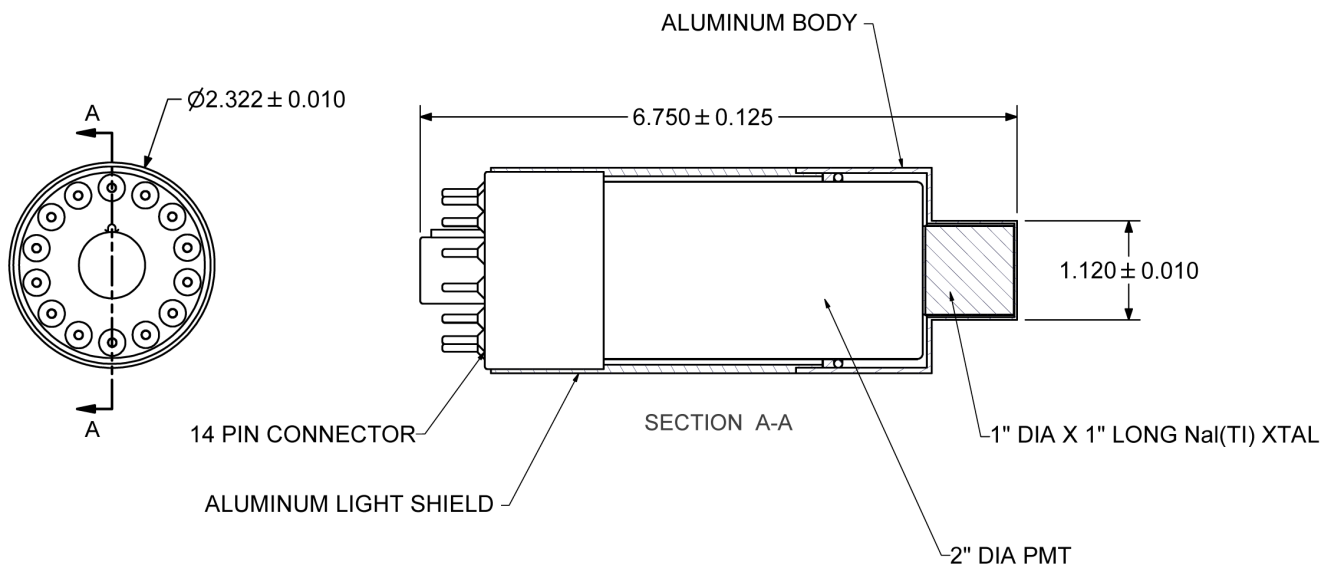

905-3 NaI Scintillation Detector, 2- x 2-in. crystal, 2-in. tube

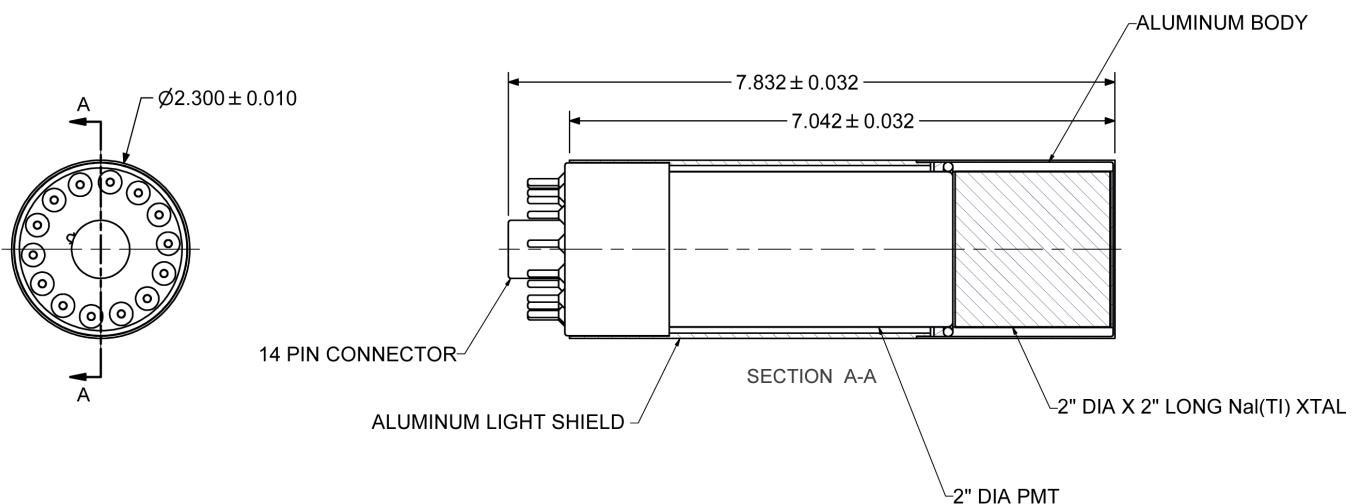

NOTE: Specifications are subject to slight variation depending on the original manufacturer.

905 Series NaI(Tl) Scintillation Detectors

905-4 NaI Scintillation Detector, 3- x 3-in. crystal, 3-in. tube

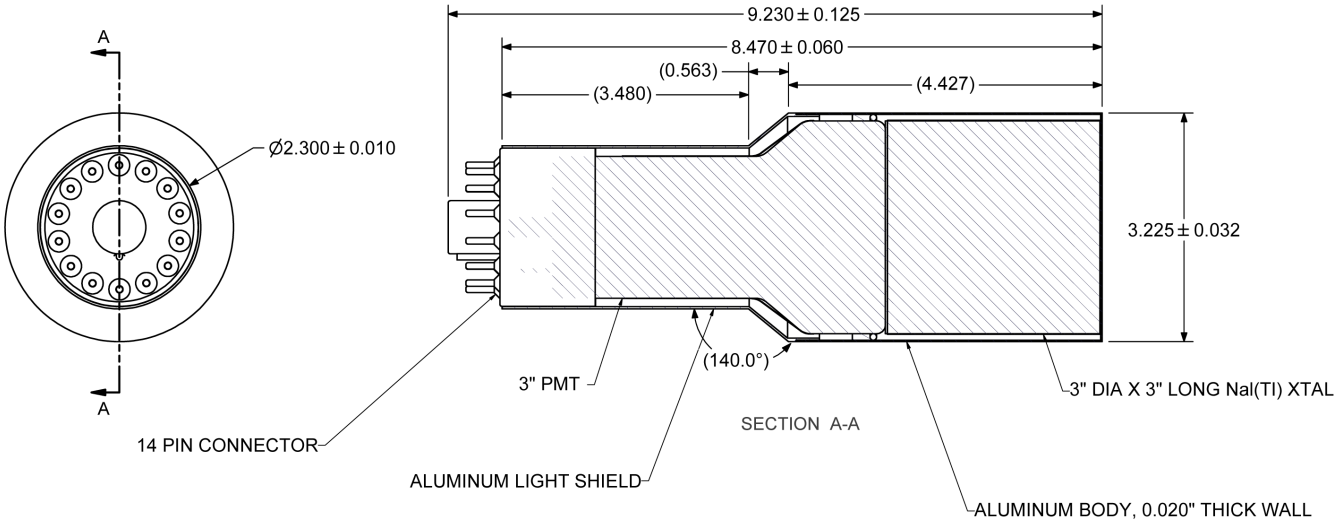

905-16 NaI Scintillation Detector, 4- x 4-in. crystal, 3-in. tube

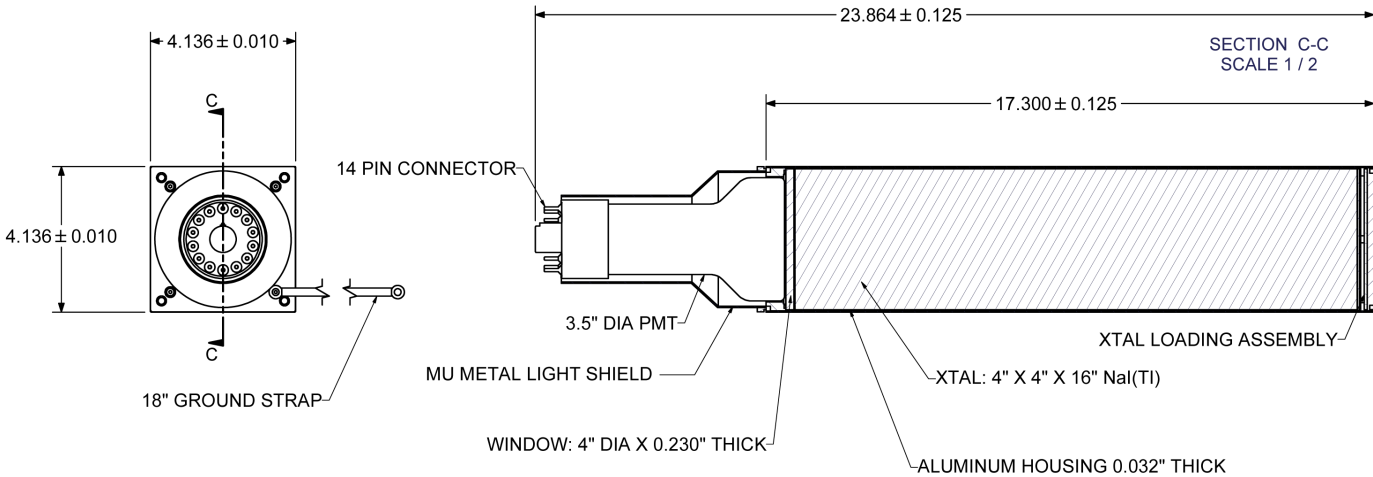

NOTE: Specifications are subject to slight variation depending on the original manufacturer.

905 Series NaI(Tl) Scintillation Detectors

Ordering Information

Model	Description
905-1	NaI Scintillation Detector, 1- x 1-in. crystal, 2-in. PMT
905-3	NaI Scintillation Detector, 2- x 2-in. crystal, 2-in. PMT
905-4	NaI Scintillation Detector, 3- x 3-in. crystal, 3-in. PMT
905-16	NaI Scintillation Detector, 4- x 4-in. crystal, 3-in. PMT
Lead Shield G-5	Table top lead shield with cable-way. A clamp mechanism is provided to hold the Detector/PMT assembly in place with room for any of the ORTEC PMT bases to be coupled to the PMT (see drawing). Shipping weight: 300 lbs. (Not compatible with 905-16 detector.)

NOTE: NaI detectors are not CE compliant and must be ordered as a Special if CE compliance is required.

