

- Four 8-decade counters with full computer control and readout CCNIM™
- One counter that can function as a presettable timer or counter
- One counter can function as a timer
- 100-MHz negative or 25-MHz positive input count rate
- RS-232-C interface
- Crystal-controlled time base
- Auto Recycle dwell time control

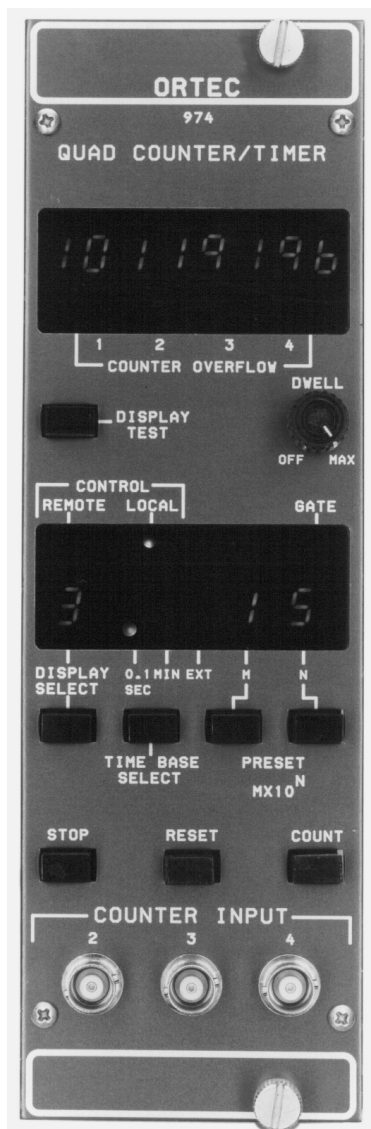

The ORTEC Model 974A is a four-channel, 100-MHz Counter/Timer in a CCNIM™ (computer-controlled NIM) package. It can be computer-controlled or manually operated. The Model 974A may be used as a three-channel counter with one presettable timer, a four-channel counter (one counter channel presettable), or as a three-channel counter (one counter channel presettable) with one timer. Any one of the four 100-MHz counter/timer channels can be monitored on the large, 8-decade LED display. In addition to the four 100-MHz channels, the Model 974A incorporates an 8-decade, presettable Event counter that can only be controlled or read through the computer interface.

Standard computer interfaces built in to the Model 974A include the RS-232-C and 20-mA loop. The command format (Table 1) adheres to the Standard NIM Digital Bus*, an easy-to-use language for programming NIM instruments. All front-panel functions (with the exception of Display Test) may be remotely controlled via a computer or dumb-terminal. In addition, several functions not accessible via the front panel are accessible with the computer interfaces. The front panel may be locked out by the ENABLE_REMOTE command from a terminal or computer.

The input polarity to each of the four counting channels may be independently set using internal connectors. The maximum count rate for negative signals is 100 MHz; the maximum count rate for positive signals is 25 MHz. Each counting channel can be independently, externally gated through the Gate 1, 2, 3, and 4 inputs. All four counting channels may be simultaneously, externally gated through the Master Gate input.

The architecture of the ORTEC Model 974A Quad 100-MHz Counter/Timer (Fig. 1) is designed for maximum flexibility. Counter channel 1 acts as the gate controller for counter channels 1, 2, 3, and 4.

When counting is started, the input gates to counting channels 1, 2, 3, and 4 are opened.

When the accumulated counts in counting channel 1 equal the selected preset value (selected and displayed on the front panel), the counting interval is terminated and the input gates to counting channels 1, 2, 3, and 4 are closed. If the Dwell control is turned fully counter-clockwise to the Off position, no new counting cycle will be initiated. If, however, the Dwell control is set for a chosen dwell time, a new counting cycle will be automatically initiated after the end of the chosen dwell time and automatic reset. Since the input to counting channel 1 can be selected as the internal 0.1-second

time base, the internal 1-minute time base, or an external source, channel 1 can act as a presettable timer or a pre-settable counter.

The Event counter, which is accessible only through one of the computer interfaces, is primarily intended as a means of labeling printouts or listings of counting cycles. After the Model 974A receives an ENABLE_EVENT_AUTO command, the Event counter will increment one count at the end of each preset counting interval. The contents of the Event counter, along with the contents of each of the four 100-MHz counting channels, are output during the implementation of a SHOW_COUNTS command. This results in an integer labeling of the counting cycle printout. The Event counter may be used alternately as a counter of external pulses by using the ENABLE_EVENT_EXTERNAL command. The maximum count rate input to the Event counter must be <4 kHz; its capacity is 8 decades. The ENABLE_EVENT_PRESET command allows the Event counter to control the total number of counting cycles in a given counting run. After an Event preset value is set via computer interface, the Event counter will allow continuous counter interval recycling until the accumulated value equals the preset value. The complete command file of the Model 974A is shown in Table 1.

Specifications

PERFORMANCE

COUNT CAPACITY 8 decades, all sections.

COUNTING RATE 100 MHz for negative inputs, all sections; 25 MHz for positive inputs, all sections.

TIME BASE 0.1-second or 1-minute increments derived from an internal 1-MHz crystal-controlled oscillator. Also accepts external input through rear-panel BNC labeled Ext In. Selectable from front panel or through computer control.

PULSE PAIR RESOLUTION 10 ns for negative inputs, 40 ns for positive inputs.

INDICATORS

COUNTER DISPLAY 8 characters, 7 LED segments per character plus decimal point.

TIMER PRESET 2 characters, 7 LED segments per character. Presettable from front panel or through computer control. Displayed in an M X 10^N format.

DISPLAYED COUNTER Single-digit display indicates which counter channel is being displayed.

*Please refer to "Standard NIM Digital Bus (NIM/488)," DOE/ER-0457T, U.S. NIM committee, May 1990; Standard NIM Instrumentation System, NTIS, U.S. Department of Commerce, Springfield, Virginia 22161.

974A

CCNIM Quad 100-MHz Counter/Timer

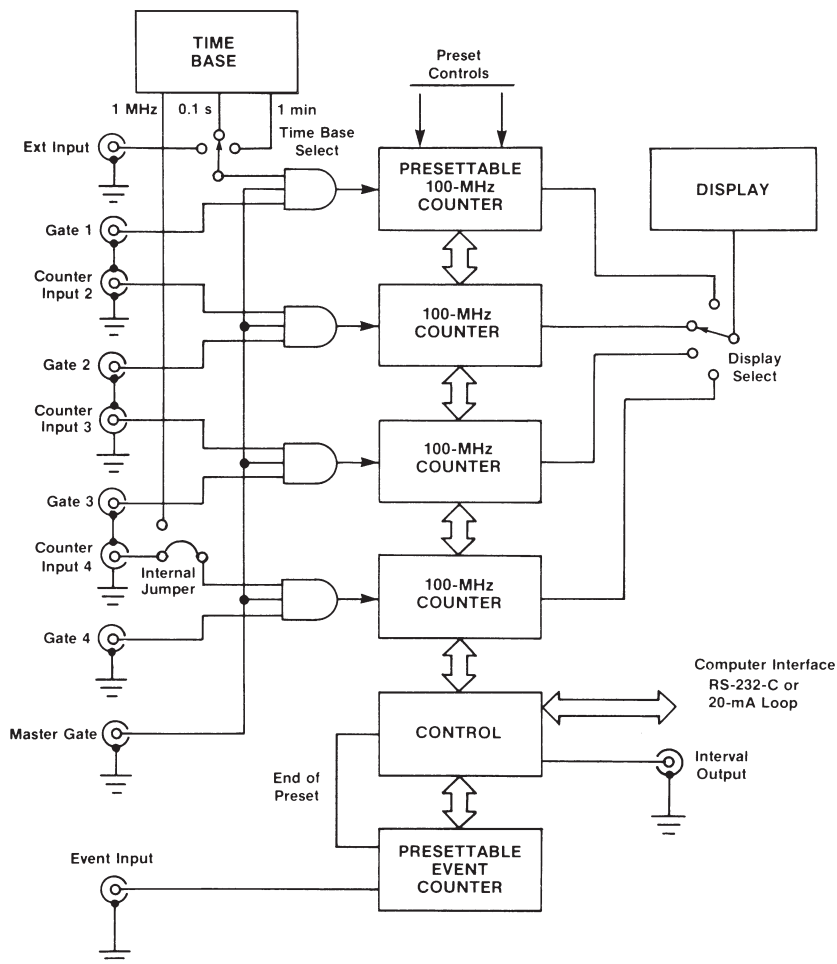

Fig. 1. ORTEC Model 974A Counter/Timer Architecture.

Table 1. Model 974A Standard NIM Digital Bus Commands.

CLEAR_ALL	SET_MODE_MINUTES
CLEAR_COUNTERS <MASK>	SET_MODE_SECONDS
CLEAR_COUNT_PRESET	SET_DISPLAY <VALUE>
CLEAR_EVENT_PRESET	SHOW_COUNTS <MASK>
COMPUTER SHOW_ALARM	SHOW_COUNT_PRESET
DISABLE_ALARM	SHOW_DISPLAY
DISABLE_EVENT	SHOW_EVENT
DISABLE_EVENT_PRESET	SHOW_EVENT_PRESET
DISABLE_TRIGGER_START	SHOW_MODE
DISABLE_TRIGGER_STOP	SHOW_RADIX
ENABLE_ALARM	SHOW_VERSION
ENABLE_EVENT_AUTO	SET_RADIX_BINARY
ENABLE_EVENT_EXTERNAL	SET_RADIX_DECIMAL
ENABLE_EVENT_PRESET_INIT	START
ENABLE_LOCAL	STOP
ENABLE_REMOTE	TERMINAL
ENABLE_TRIGGER_START	TEST NUMBER
ENABLE_TRIGGER_STOP	
SET_COUNT_PRESET M,N	
SET_EVENT_PRESET <VALUE>	
SET_MODE_EXTERNAL	

CONTROL 2 LEDs indicating either Remote mode operation (front-panel controls locked out) or Local mode operation (front-panel controls operative).

0.1 SEC Single LED illuminates when the 0.1-second time base is selected.

1 MIN Single LED illuminates when 1-minute time base is selected.

EXT Single LED illuminates when Ext time base is selected or when using counter channel 1 as a counter.

COUNTER OVERFLOW 1, 2, 3, AND 4 Four separate LEDs illuminate when the corresponding counting channel exceeds the capacity of the counting channel.

GATE Single LED illuminates during an active counting interval.

CONTROLS

DISPLAY TEST Push-button switch illuminates all segments of every 7-segment display.

RESET Push-button switch resets the internal counting channels to zero and turns Off the overflow indicators.

STOP Push-button switch selects the noncounting condition for all counting channels.

COUNT Push-button switch enables the counting condition for all counting channels provided the Gate input is not held below +1.5 V and the time is not at the preset count condition.

DISPLAY SELECT Push-button switch selects the counting channel whose contents will be displayed.

DWELL TIME Single-turn control with a switch at the full counterclockwise setting for Off. Off inhibits recycle operation of a preset counting interval. When the control is turned clockwise away from Off, it permits recycling with a dwell time between counting intervals that can be adjusted from 0.3 s to ~15 s. This control is disabled when computer control is in effect.

M Push-button switch used to set the timer preset value. The "M" preset value [preset = (M X 10^N) time base] is incremented each time the button is pressed. Maximum value = 9.

N Push-button switch used to set the timer "N" preset value. The N preset value is incremented each time the button is pressed. Maximum value = 7.

TIME BASE SELECT Push button used to select the internal time base of 0.1 Sec or 1 Min or the Ext In rear-panel input for external time base.

SERIAL INTERFACE CONTROL (S-2) An 8-position slide switch accessible through a cutout in the left side panel. Sections 1 through 4 select the counting channels whose contents will be transmitted when data is transferred to the

computer or terminal. If the corresponding switch is set for print, the data for that counting channel will be transmitted; if set to the skip position, the data will not be transmitted. Section 5 selects the length of the data byte that will be transmitted over the serial communications interface. "On" selects 7 data bits; "Off" selects 8 data bits. Section 6 is used to enable or disable the parity generation and checking when characters are sent or received over the serial interface. If parity is enabled, Section 7 selects either odd or even parity mode. Section 8 selects whether one or two stop bits are added to the character transmitted over the serial interface.

BAUD RATE SELECT (S-3) A 4-position slide switch accessible through a cutout in the left side panel. This switch selects the baud rate at which characters are transmitted and received over the serial communications interface.

INPUTS

COUNTERS 2, 3, AND 4 Front-panel BNC connectors accept positive unipolar signals; minimum pulse width above threshold, 20 ns at 50% duty cycle. $Z_{in} = 1\text{ k}\Omega$ to ground. Threshold is fixed at +1.5 V. Input protected to +25 V, dc-coupled.

Changing the input connector to the counter board permits independent selection of NIM-standard fast negative logic pulses, 14 mA into 50 Ω . Minimum pulse width above threshold is 4 ns. Input is dc-coupled, 250-mV fixed threshold.

COUNTER 1 OR EXT Rear-panel BNC connector accepts NIM-standard positive unipolar signals; minimum pulse width above threshold, 20 ns at 50% duty cycle. $Z_{in} = 1\text{ k}\Omega$ to ground. Threshold is fixed at +1.5 V. Input protected to +25 V, dc-coupled.

Changing the input connector to the negative input permits selection of NIM-standard negative logic pulses, 14 mA into 50 Ω . Minimum pulse

width above threshold is 4 ns; threshold fixed at -250 mV; input is dc-coupled.

MASTER GATE Rear-panel BNC connector accepts NIM-standard positive logic signal to control counter input gate for all counting sections and the front-panel count LED indicator. A signal >+3 V or open circuit allows counting; a level of <+1.5 V inhibits counting. Protected to +25 V. Driving source must be capable of sinking 0.5 mA positive current during inhibit.

GATES 1, 2, 3, AND 4 Rear-panel BNC connectors accept NIM-standard positive logic signal to control individual counting channel inputs. A signal >+3 V or open circuit allows counting; 25 V maximum. A level of <+1.5 V inhibits counting. Driving source must be capable of sinking 0.5 mA of positive current during inhibit.

EVENT Rear-panel BNC connector accepts standard positive logic pulse to increment the event counter. Signal must exceed a level of +2.5 V for a period of >100 ns to increment the event counter. Maximum frequency of input signal is 4 kHz.

RESET Rear-panel BNC connector accepts standard positive logic pulse to remotely reset all counting sections to zero. A signal of >+3 V is needed to reset; a signal of <+1.5 V or open circuit is required to not reset. Protected to +25 V; minimum pulse width is 100 ns; $Z_{in} = 6\text{ k}\Omega$ to ground, dc-coupled.

OUTPUT

INTERVAL Rear-panel BNC connector furnishes a positive level during the counting interval. Nominally +5 V; $Z_o = 30\text{ }\Omega$.

INTERFACE

SERIAL RS-232-C or 20-mA current loop signal on a single, 25-pin rear-panel-mounted connector.

ELECTRICAL AND MECHANICAL

POWER REQUIRED +6 V, 1.6 A; +12 V, 70 mA; -12 V, 290 mA.

WEIGHT

Net 2.4 kg (5.2 lb).

Shipping 3.7 kg (8.2 lb).

DIMENSIONS NIM-standard double-width module 6.90 X 22.13 cm (2.70 X 8.714 in.) front panel per DOE/ER-0457T.

Ordering Information

Model	Description
974A	Quad 100-MHz Counter/Timer

OPTIONAL CABLE ASSEMBLIES

Model	Description
C-75	Female-to-female RS-232-C null modem cable (3-meter length)
C-80	Male-to-female RS-232-C extension cable (3-meter length)

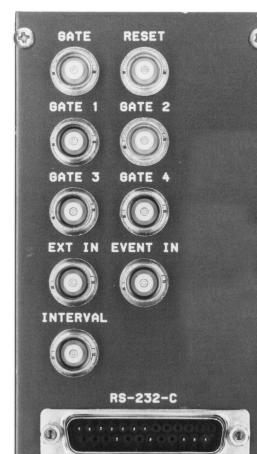

974A

CCNIM Quad 100-MHz Counter/Timer



www.ortec-online.com

Tel. (865) 482-4411 ortec.info@ametek.com
801 South Illinois Avenue, Oak Ridge, TN 37830 U.S.A.
Visit Our Website For International Office Locations

Specifications subject to change
25-0519