

GAMMA-X: N-type Coaxial HPGe Detectors for Gamma Spectroscopy down to ~5 keV

The GAMMA-X detector is a coaxial Germanium (Ge) detector with an ultra-thin entrance window. While most coaxial detectors have entrance windows from 500- to 1000- μm thick, the entrance window of the GAMMA-X detector is a 0.3- μm -thick, ion-implanted contact, extending the lower range of useful energies to around 5 keV. Ion implantation results in a totally stable contact which will not deteriorate with repeated cycling. Moreover, N-type HPGe detectors have been shown to be resistant to damage by fast neutrons.

All GAMMA-X Series detectors feature:

- Efficiencies to 100%, higher on request.
- Spectroscopy from 5 keV to 10 MeV.
- Thin boron ion implanted radiation window, ideal for Compton Suppression systems.
- Neutron damage resistant; user self-repair neutron damage option.
- Excellent energy resolution and peak symmetry.
- SMART bias option.
- Aluminum or carbon fiber window.
- Low-background carbon fiber endcap option.
- PLUS preamplifier option for ultra-high-rate applications.
- Configuration flexibility: PopTop, Streamline, and mechanically cooled options.

GAMMA-X Series detectors are manufactured from ORTEC-grown germanium crystals processed in our advanced manufacturing facility in Oak Ridge, TN. The detectors are fabricated from N-type germanium with an inner contact of diffused Li and an outer, ultra thin, contact of ion-implanted boron.

The wide energy range of application of the GAMMA-X detector is illustrated in Figure 1 which compares the relative efficiencies of a GAMMA-X, a GEM (P-type coaxial), and a GLP planar detector. The GAMMA-X detector, uniquely, demonstrates excellent efficiency at both high and low energies.

ORTEC offers GMX Series HPGe detectors with relative efficiencies from 10% to 100% and beyond.

ORTEC maintains a large stocklist of HPGe detectors. Some of these have "super specifications," that is, energy resolution and/or efficiency better than the usual warranted specifications.

High-Voltage Shutdown and High-Rate Indicator

GAMMA-X detectors have high-voltage shutdown and high-rate indicator protection features. If the detector begins to warm while high-voltage bias is applied, the high voltage automatically shuts off, thus protecting the FET from damage.

This is accomplished with a temperature sensor (located on the mount behind the detector) that shuts down the high voltage before the molecular sieve can outgas and cause a dangerous high-voltage arc. Using the high-leakage current of a warming detector to shut down the high voltage can result in FET and detector damage.

Neutron Damage Resistance

In the GAMMA-X detector, electron collection is the dominant process. Fast neutrons generate hole-trapping centers; that is, negatively charged defects that trap holes but not electrons.

Therefore, the GAMMA-X detector, in which the hole collection process is of secondary importance, is basically less sensitive to radiation damage than coaxial Ge devices in which the hole collection process is of primary importance. These theoretical considerations have been experimentally confirmed.¹

Figure 3, a plot of the 1.33-MeV FWHM resolution as a function of fast neutron fluence for both a GAMMA-X and a GEM detector of the same efficiency, shows that the GAMMA-X detector is far more resistant to fast neutron radiation damage.¹ The detector temperature affects its radiation damage resistance to fast neutrons.

It should be noted that once severe radiation damage has occurred, the "longest mileage" is obtained by avoiding cycling the detector to room temperature.² This is true for either P- or N-type Ge detectors. However, for slightly damaged GAMMA-X detectors (~0.1 keV degradation), cycling, or even leaving the detector warm for an extended period, will have no unfavorable effect.³

GAMMA-X detectors should be maintained at a temperature as close to 77 K as possible to minimize the extent of radiation damage under high neutron fluence.

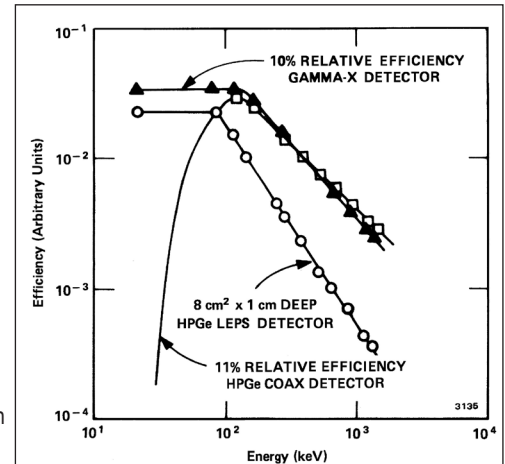

Fig. 1. Comparison of the Efficiency-Energy Curve of the LEPS, HPGe Coaxial, and GAMMA-X Detectors.

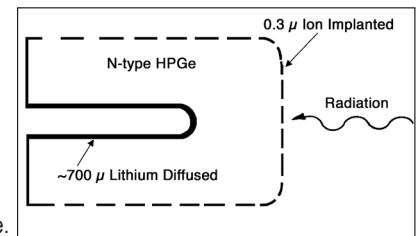

Fig. 2. Configuration of GMX Coaxial Germanium Crystal.

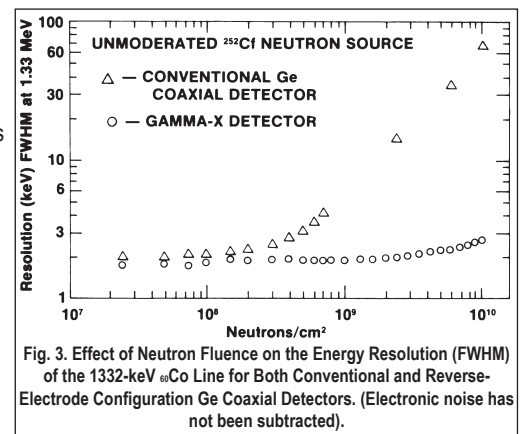

Fig. 3. Effect of Neutron Fluence on the Energy Resolution (FWHM) of the 1332-keV ^{60}Co Line for Both Conventional and Reverse-Electrode Configuration Ge Coaxial Detectors. (Electronic noise has not been subtracted).

¹R.H. Pehl, N.W. Madden, J.H. Elliott, T.W. Raudorf, R.C. Trammell, and L.S. Darken, Jr., "Radiation Damage Resistance of Reverse Electrode Ge Coaxial Detectors," IEEE Trans. Nucl. Sci. NS-26, N1, 321-23 (1979).

²H.W. Kraner, R.H. Pehl, and E.E. Haller, "Fast Neutron Radiation Damage of High-Purity Germanium Detectors," IEEE Trans. Nucl. Sci. NS-22, N1, 149 (1975).

³T.W. Raudorf, R.C. Trammell, and Sanford Wagner, "Performance of Reverse Electrode HPGe Coaxial Detectors After Light Damage by Fast Neutrons," IEEE Trans. Nucl. Sci. NS-31, N1, 253 (1984).

GMX Series Coaxial HPGe Detector Product Configuration Guide

The Following Data are Provided with each GMX Detector

- Measured energy resolution at 1.33-MeV photons from ^{60}Co .
- Measured energy resolution at 122-keV photons from ^{57}Co .
- Measured relative photopeak efficiency for a ^{60}Co 1.33-MeV peak.
- Measured Peak-to-Compton ratio for a ^{60}Co 1.33-MeV peak.
- Measured peak shape ratio for the full-width tenth-maximum to the full-width half-maximum for a ^{60}Co 1.33-MeV peak.
- Measured energy resolution at 5.9-keV.

Configuration Guidelines

PopTop or Streamline (non-PopTop) Configuration

The essence of a PopTop detector system is that the HPGe detector element cryostat, preamplifier, and high voltage filter are housed in a detector “capsule” which is then attached to an appropriate cryostat (Figure 4.)

In Streamline systems, the detector capsule is NOT demountable. Detector capsule and cryostat share the same vacuum. In configuration terms, this requires a cryostat or cryostat/dewar selection with the cryostat having a matching diameter to the capsule endcap. A cryostat must always be ordered with a Streamline capsule because they are integral.

The actual PopTop capsule has its own vacuum. It can be mounted on any of the available cryostats, cryostat/dewar combinations or the ICS-P4 mechanical cooling system.

Certain cryostat configurations are available only as PopTop and others are available only as Streamline.

Steps to Configure Your ORTEC HPGe Detector

1) Configure the Detector Model

- Capsule type (PopTop or Streamline)
- Ge Crystal efficiency and specifications
- Window material
- Mount materials
- Preamplifier
- Cooling system

Options are available for the detector model that can change specific materials used in the construction of the detector endcap, cup, and mount. Preamplifier options are also available.

2) Configure the Cryostat/Dewar or ICS Model

- Vertical Dipstick style (separate Dewar or Mobius Recycler)
- Horizontal Dipstick style (separate Dewar or Mobius Recycler)
- Portable with all-position or multi-position cryostat/dewar models
- Downlooking designed to be oriented with the detector pointing down
- Sideloooking designed to be oriented with the detector horizontal at the bottom of the dewar
- “J” configurations designed with the detector attached near the bottom of the dewar and a right angle bend in the cryostat orienting the detector to look up.

A cryostat and dewar or other cooling device are required for operation.

If a PopTop detector has been selected, you can choose a PopTop style cryostat, cryostat/dewar combination or the ICS-P4 mechanical cooling system.

If a Streamline detector has been selected, you must choose a cryostat or cryostat/dewar model for the detector to be mounted on and vacuum sealed. The cryostat or cryostat/dewar combination diameter must match the endcap diameter of the selected detector.

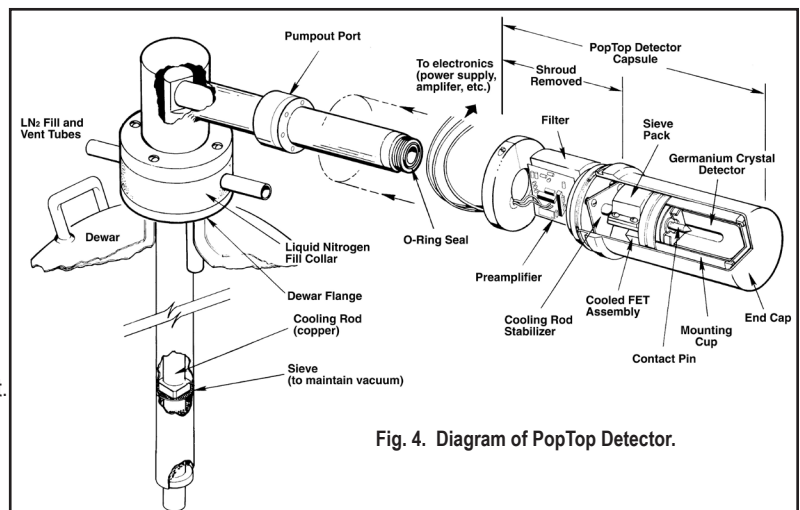

Fig. 4. Diagram of PopTop Detector.

¹By convention, HPGe detectors are characterized by “relative efficiency”. Relative efficiency is defined as the efficiency of a point Co-60 source at 25 cm from the face of a standard 3-inch x 3-inch right circular cylinder NaI(Tl) detector. “IEEE Test Procedures for Germanium Detectors for Ionizing Radiatio,” ANSI/IEEE Standard 325-1986.

GMX Series Coaxial HPGe Detector Product Configuration Guide

Detector Options

Aluminum Window Option (-A)

An all Aluminum endcap can be chosen if the energies of interest exceed 20 keV. See Table 1 for the transmission data for Aluminum.

Carbon Fiber Window Option (-CW)

Carbon fiber has lower Z than Aluminum and does not have any of the hazards associated with Beryllium. GMX series carbon fiber windows are only 0.76 mm thick, but extremely rugged. See Table 1 for transmission data for carbon fiber.

Ultra-High Count-Rate Preamplifier Option (-PL)

The Ultra-High Count-Rate Preamplifier (transistor-reset preamplifier), which can handle input count rates up to 1,000,000 counts/s at 1 MeV, offers the added benefit of having no feedback resistor.

SMART-1 Option (-SMN)

The SMART-1 option monitors and reports on vital system functions, and can save authentication codes and report the code at a later time. It has the high voltage included, so none of the instruments require an external high-voltage power supply.

The SMART-1 is housed in a rugged ABS molded plastic enclosure and is permanently attached to the detector endcap via a molded-strain-relieved sealed cable. This eliminates the possibility that the detector will suffer severe damage from moisture leaking into high-voltage connectors. The SMART-1 can be positioned in any convenient place and does not interfere with shielding or other mounting hardware.

Remote Preamplifier Option (-HJ)

This option allows all the preamplifier and high voltage connections to be outside a shield and removes the preamplifier and high voltage filter from the "line-of-sight" to the Ge crystal. For low background applications, this option eliminates any possible preamplifier or high voltage filter components that may add to the background inside a shield.

Low-Background Carbon Fiber Endcap Options (-RB, -LB-C, and -XLB-C)

Carbon Fiber is as strong as Al, Mg, and Cu, creates less background, does not corrode, and can pass photons with energies less than 10 keV.

This lower background material allows for lower Minimum Detectable Activity (MDA) for a specific counting time, which provides another step in increasing sample throughput in low-background counting applications. The lower Z of Carbon Fiber provides a low-energy window without the additional background found in most alloys.

Energy (keV)	Aluminum Window % Transmission	Carbon Fiber Window % Transmission
3	0	0.29
5	0	23
10	0.09	82
20	40	97
30	74	99
50	91	100
80	95	100
100	96	100
400	97	100
1000	98	100



Fig. 5. SMART-1 Detector Interface Module.

GMX Series Coaxial HPGe Detector Product Configuration Guide

PopTop Detector Capsule

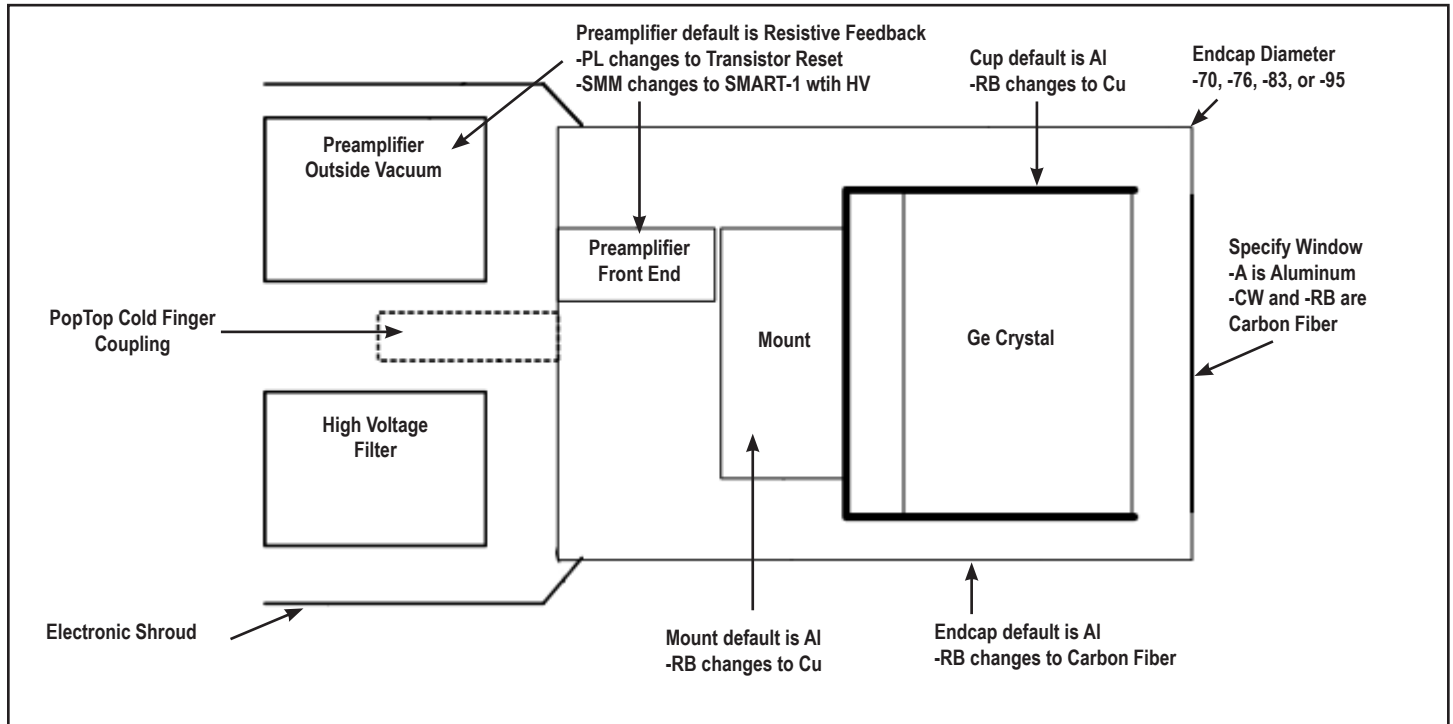

Streamline Detector Capsule

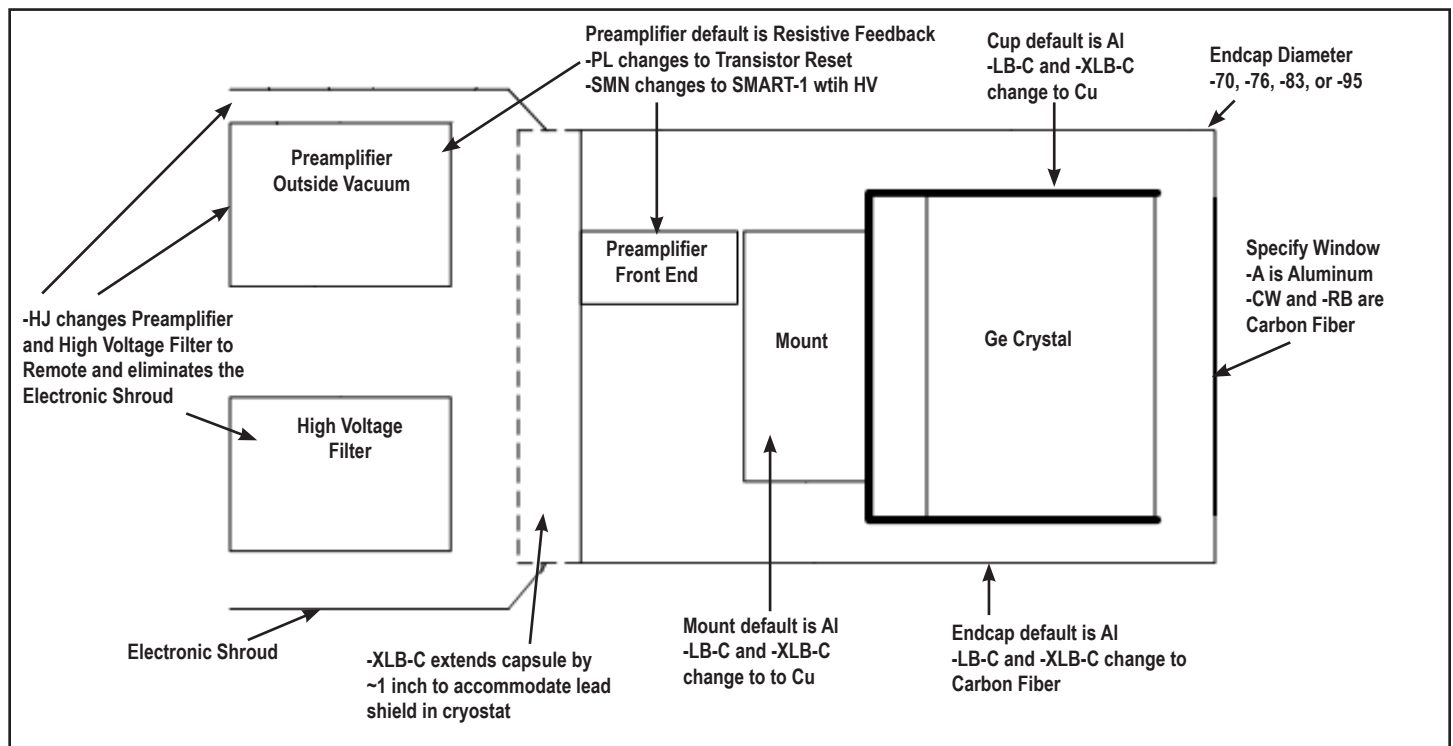

GMX Series Coaxial HPGe Detector Product Configuration Guide

Streamline Cryostat and Cryostat/Dewar Assemblies

Streamline systems (detector capsule and cryostat) share the same vacuum, requiring a cryostat or cryostat/dewar selection with the cryostat having a matching diameter to the capsule endcap.

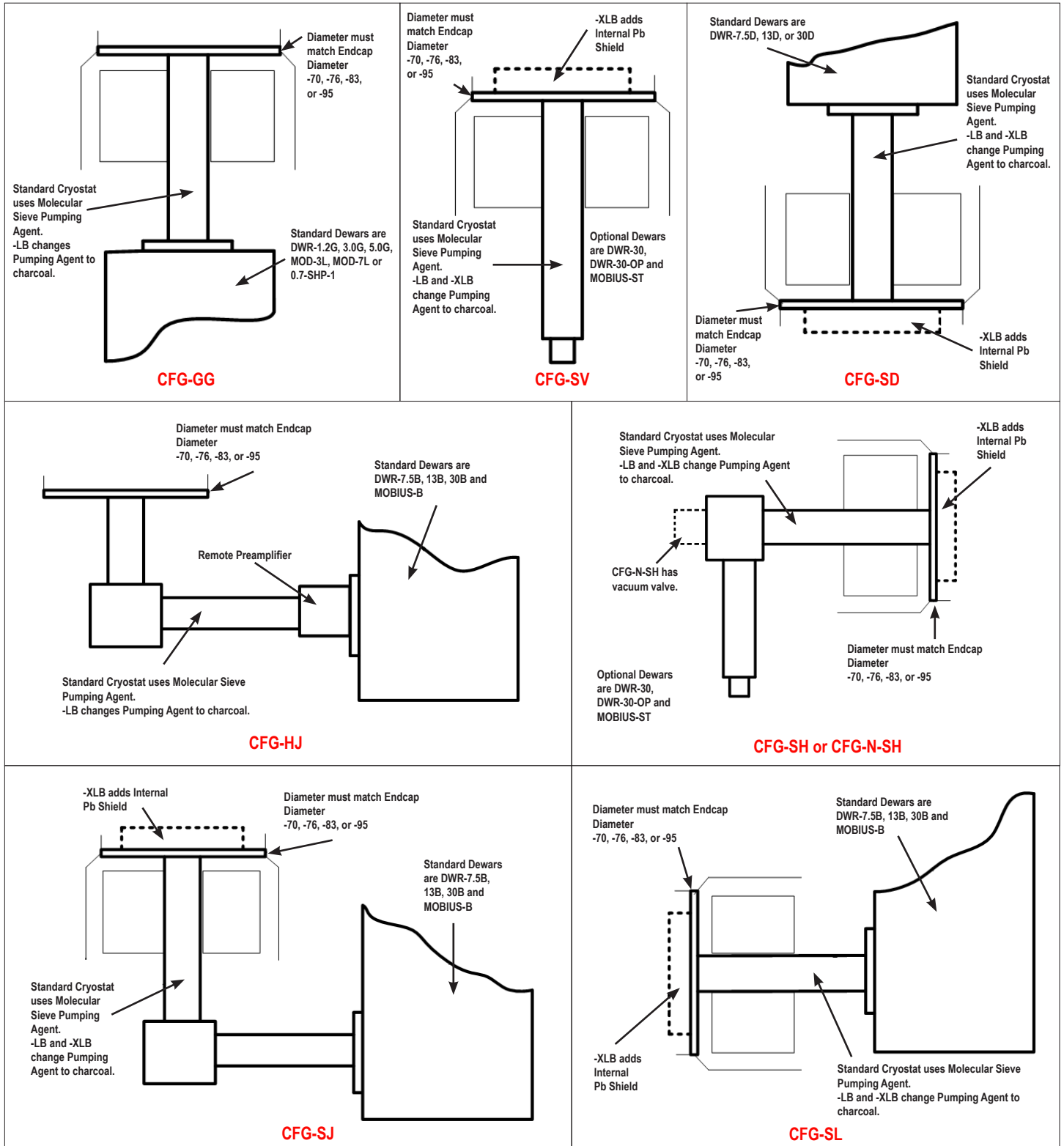

GMX Series Coaxial HPGe Detector Product Configuration Guide

PopTop and Streamline Dimensional Data

Streamline systems (detector capsule and cryostat) share the same vacuum. A cryostat must be ordered with a Streamline capsule. The cryostat or cryostat/dewar selection must have a matching diameter to the capsule endcap.

The PopTop capsule features an internal vacuum arrangement. It can be mounted on any of the available PopTop cryostats, cryostat/dewar combinations, or ICS-P4 mechanical cooling systems.

The cryostat and dewar drawings that follow are to be used in conjunction with the accompanying tables of dimensions.

**Note: Cryostat/Dewar drawings are NOT to scale, see tables that follow for complete dimensions.
Dimensions are for reference only and subject to change, if dimensional constraints are critical, contact the factory.**

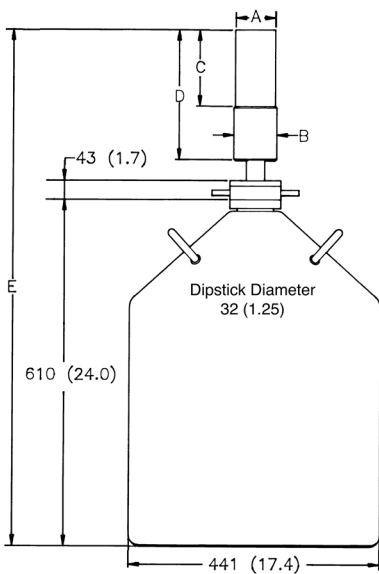

CFG-SV, DWR-30

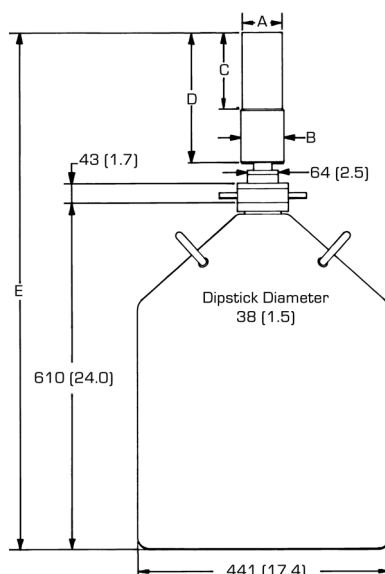

CFG-PV4, DWR-30

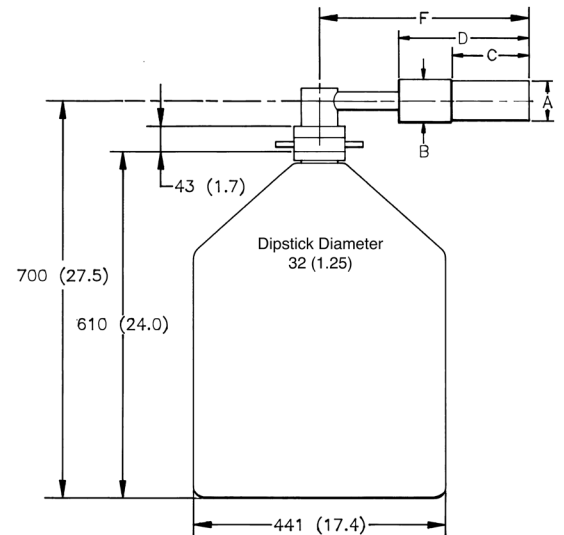

CFG-SH, DWR-30

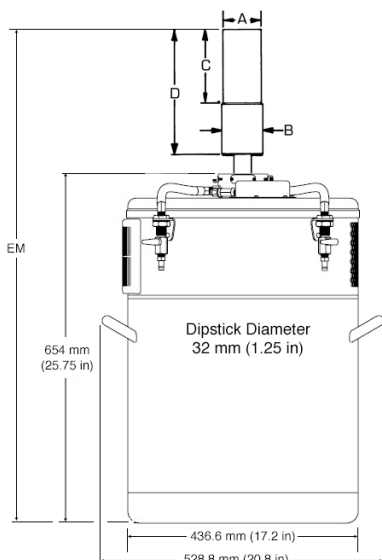

CFG-SV, MOBIUS-ST

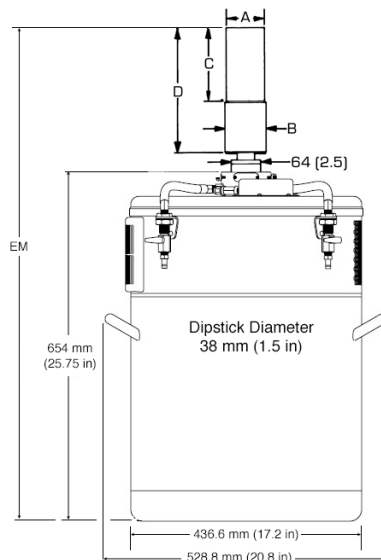

CFG-PV4, MOBIUS-ST

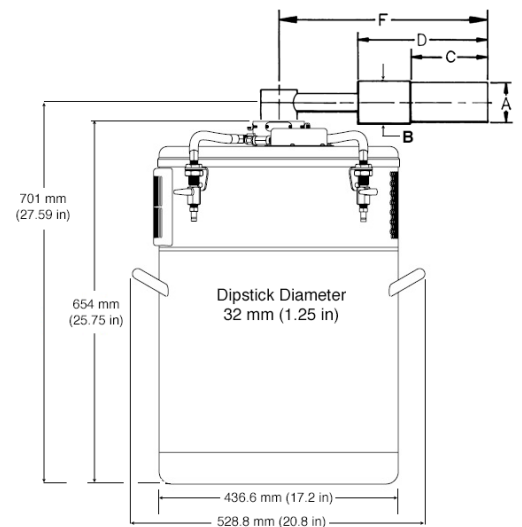

CFG-SH, MOBIUS-ST

GMX Series Coaxial HPGe Detector Product Configuration Guide

Note: Cryostat/Dewar drawings are NOT to scale, see tables that follow for complete dimensions. Dimensions are for reference only and subject to change, if dimensional constraints are critical, contact the factory.

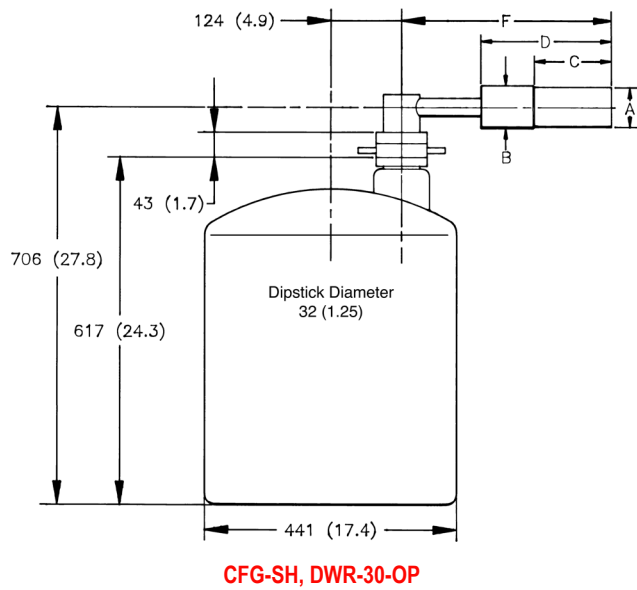
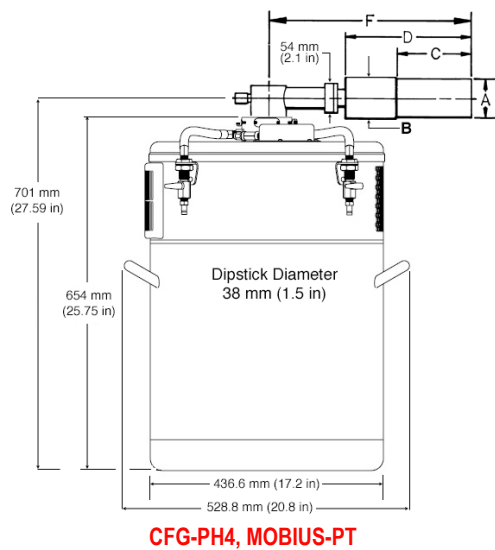
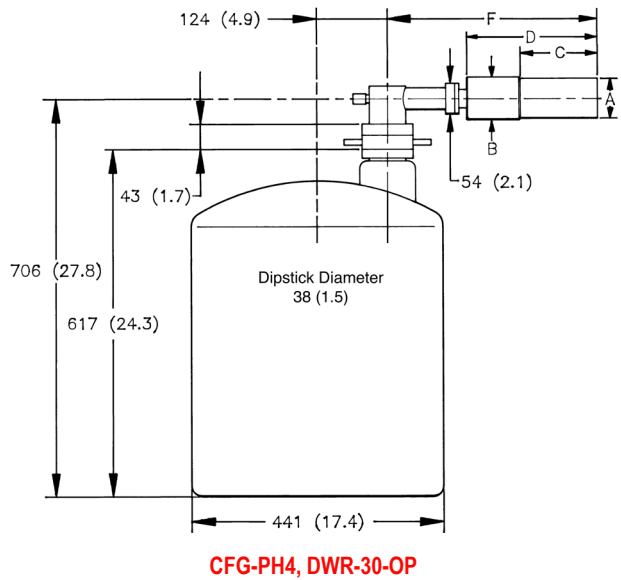
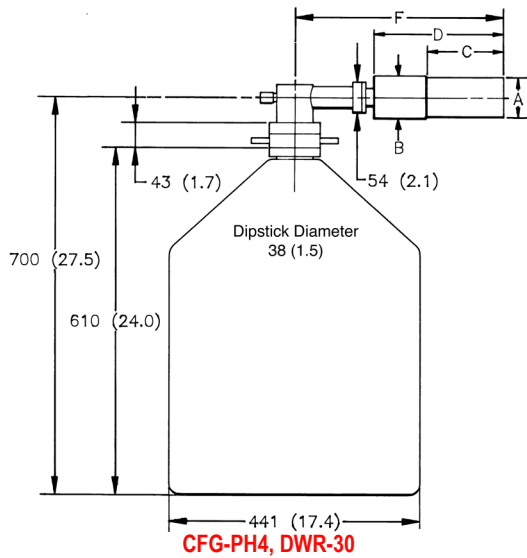

GMX Series Coaxial HPGe Detector Product Configuration Guide

**Note: Cryostat/Dewar drawings are NOT to scale, see tables that follow for complete dimensions.
Dimensions are for reference only and subject to change, if dimensional constraints are critical, contact the factory.**

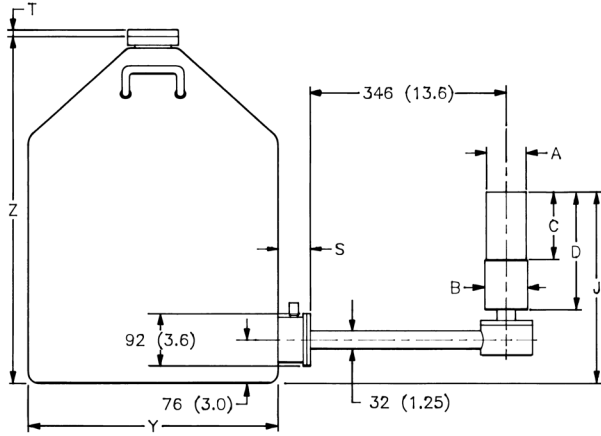

CFG-SJ, DWR-30B (or -13B or -7.5B)

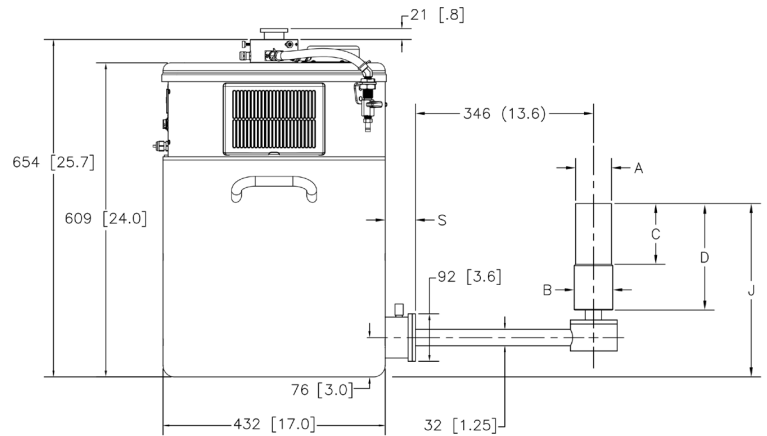

CFG-SJ, MOBIUS-B

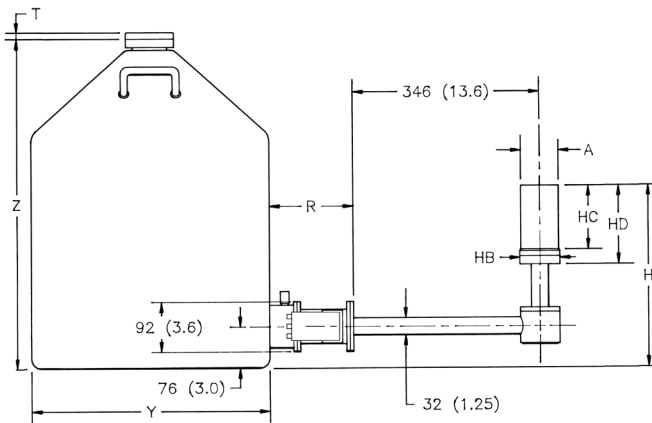

CFG-HJ, DWR-30B (or -13B or -7.5B)

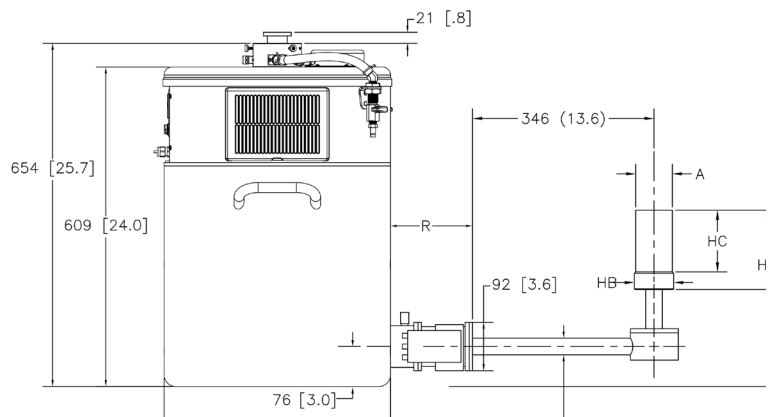

CFG-HJ, MOBIUS-B

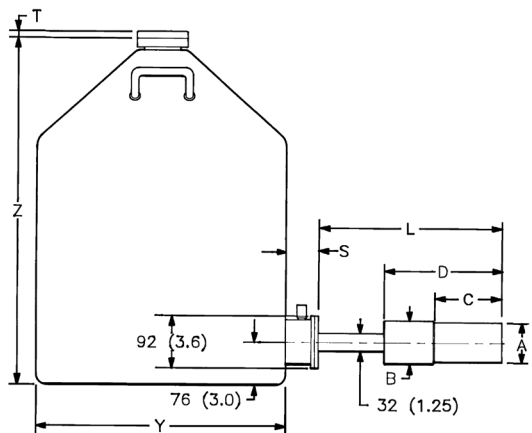

**CFG-PS4-30 (or -13 or -7.5) or
CFG-SL, DWR-30B (or -13B or -7.5B)**

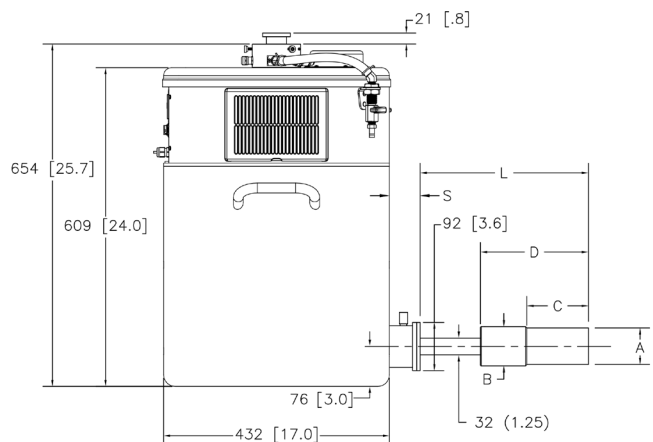

CFG-PS4-MOBIUS-B or CFG-SL, MOBIUS-B

GMX Series Coaxial HPGe Detector Product Configuration Guide

Note: Cryostat/Dewar drawings are NOT to scale, see tables that follow for complete dimensions.
Dimensions are for reference only and subject to change, if dimensional constraints are critical, contact the factory.

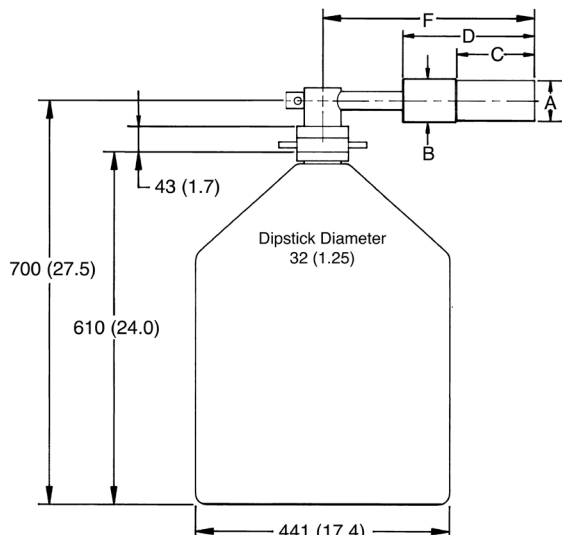

CFG-N-SH, DWR-30

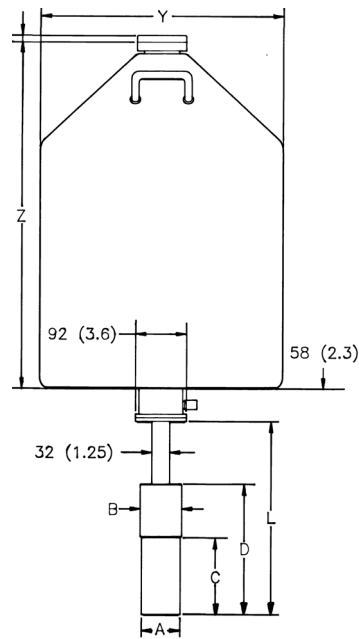

**CFG-PD4-30 (or -13 or -7.5) or
CFG-SD, DWR-30D (or -13D or -7.5D)**

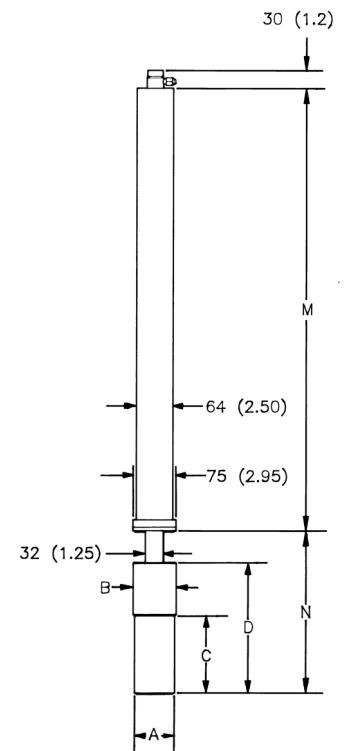

**CFG-PSHP4 or
CFG-GG, DWR-0.7-SHP-1**

GMX Series Coaxial HPGe Detector Product Configuration Guide

**Note: Cryostat/Dewar drawings are NOT to scale, see tables that follow for complete dimensions.
Dimensions are for reference only and subject to change, if dimensional constraints are critical, contact the factory.**

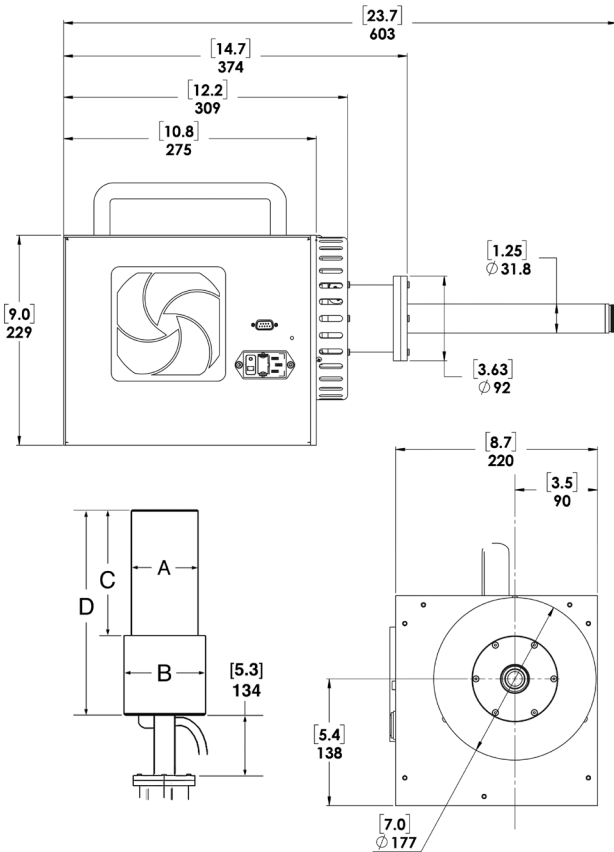

CFG-ICS-P4

PopTop GMX Series Detector Dimensions

- Dimensions are for reference only and subject to change.
- If dimensional constraints are critical, contact the factory.

Endcap Model (dia. mm)			-70	-76	-83	-95
% Efficiencies available in this endcap size			0-20	25-40	45-55	60-100
Dim.	Unit	Tol.				
A	mm (in)	0.3 (0.01)	70 (2.75)	76 (3.0)	83 (3.25)	95 (3.75)
B	mm (in)	0.3 (0.01)	75 (2.95)	88 (3.45)	88 (3.45)	100 (3.95)
C	mm (in)	5 (0.2)	134 (5.3)	165 (6.4)	168 (6.6)	193 (7.6)
D	mm (in)	8 (0.3)	250 (9.8)	282 (11.2)	282 (11.2)	309 (12.2)
E	mm (in)	18 (0.7)	947 (37.3)	982 (38.6)	982 (38.6)	1007 (39.7)
EM	mm (in)	19 (0.75)	948 (37.3)	983 (38.7)	983 (38.7)	1008 (39.7)
F	mm (in)	10 (0.4)	396 (15.6)	429 (16.9)	429 (16.9)	455 (17.9)
L	mm (in)	10 (0.4)	338 (13.3)	371 (14.6)	371 (14.6)	396 (15.6)
M	mm (in)	8 (0.3)	790 (31.1)	X X	X X	X X
N	mm (in)	10 (0.4)	278 (10.9)	312 (12.3)	312 (12.3)	338 (13.3)

GMX Series Coaxial HPGe Detector Product Configuration Guide

Streamline GMX Series Detector Dimensions

- Dimensions are for reference only and subject to change.
- If dimensional constraints are critical, contact the factory.

			Standard or LB				XLB			
Endcap Model (dia. mm)			-70	-76	-83	-95	-70	-76	-83	-95
% Efficiencies available in this endcap size			0-20	25-40	45-55	60-100	0-20	25-40	45-55	60-100
Dim.	Unit	Tol.								
A	mm (in)	0.3 (0.01)	70 (2.75)	76 (3.0)	83 (3.25)	95 (3.75)	70 (2.75)	76 (3.0)	83 (3.25)	95 (3.75)
B	mm (in)	0.3 (0.01)	75 (2.95)	88 (3.45)	88 (3.45)	100 (3.95)	75 (2.95)	88 (3.45)	88 (3.45)	100 (3.95)
C	mm (in)	5 (0.2)	134 (5.3)	132 (5.2)	134 (5.3)	160 (6.3)	160 (6.3)	157 (6.1)	160 (6.3)	185 (7.3)
D	mm (in)	8 (0.3)	246 (9.7)	259 (10.2)	259 (10.2)	284 (11.2)	272 (10.7)	284 (11.2)	284 (11.2)	310 (12.2)
E	mm (in)	18 (0.7)	916 (36.1)	932 (36.7)	932 (36.7)	957 (37.7)	941 (37.1)	958 (37.7)	958 (37.7)	983 (38.7)
EM	mm (in)	19 (0.75)	917 (36.1)	933 (36.7)	933 (36.7)	958 (37.7)	942 (37.1)	959 (37.8)	959 (37.8)	984 (38.7)
F	mm (in)	10 (0.4)	368 (14.5)	381 (15.0)	381 (15.0)	406 (16.0)	394 (15.5)	406 (16.0)	406 (16.0)	432 (17.0)
H	mm (in)	18 (0.7)	351 (13.8)	364 (14.3)	364 (14.3)	390 (15.3)	X X	X X	X X	X X
HB	mm (in)	0.3 (0.1)	73 (2.9)	85 (3.4)	85 (3.4)	98 (3.9)	X X	X X	X X	X X
HC	mm (in)	5 (0.2)	134 (5.3)	132 (5.2)	135 (5.3)	160 (6.3)	X X	X X	X X	X X
HD	mm (in)	10 (0.4)	162 (6.4)	175 (6.9)	175 (6.9)	200 (7.9)	X X	X X	X X	X X
J	mm (in)	10 (0.4)	380 (15)	393 (15.5)	393 (15.5)	418 (16.5)	405 (16)	418 (16.5)	418 (16.5)	444 (17.5)
L	mm (in)	10 (0.4)	338 (13.3)	351 (13.8)	351 (13.8)	376 (14.8)	363 (14.3)	376 (14.8)	376 (14.8)	401 (15.8)
M	mm (in)	8 (0.3)	516 (20.3)	X X	X X	X X	516 (20.3)	X X	X X	X X
N	mm (in)	10 (0.4)	278 (11)	292 (11.5)	292 (11.5)	318 (12.5)	305 (12)	318 (12.5)	318 (12.5)	243 (13.5)

GMX Series Coaxial HPGe Detector Product Configuration Guide

Note: Cryostat/Dewar drawings are NOT to scale, see tables that follow for complete dimensions.
Dimensions are for reference only and subject to change, if dimensional constraints are critical, contact the factory.

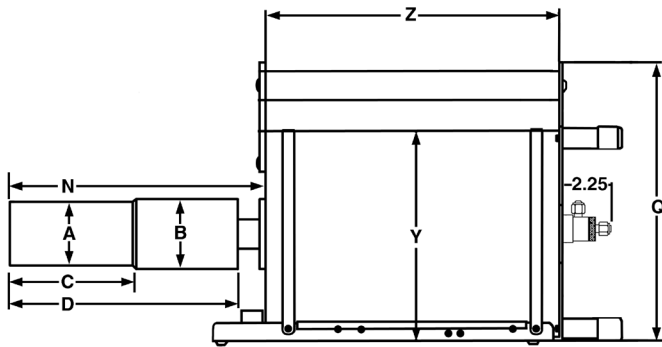

CFG-PG4-1.2 (or -3 or -5) or
CFG-GG, DWR-1.2G (or -3.0G, -5.0G)

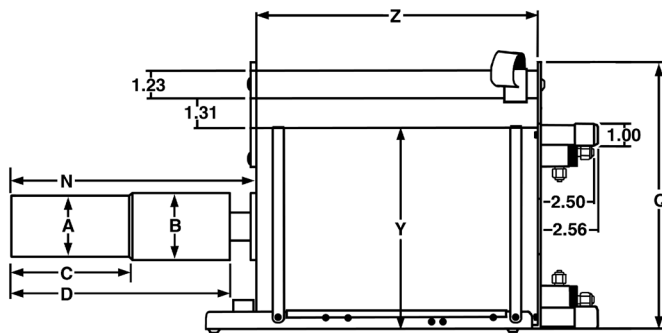

CFG-PMOD4-3 (or -7) or
CFG-GG, DWR-MOD3L (or -MOD7L)

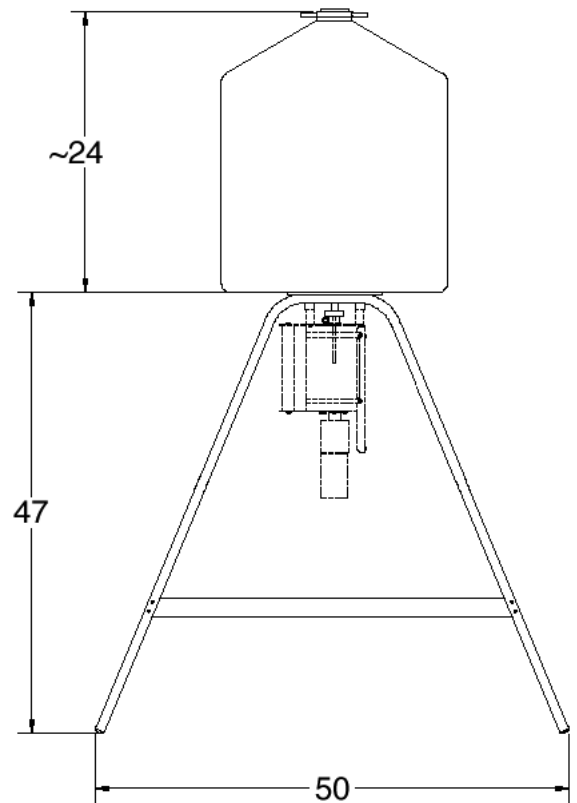

DWR-S/F

Gamma Gage and Side-Looking Dewar Dimensions

- Dimensions are for reference only and subject to change.
- If dimensional constraints are critical, contact the factory.

			Cryostat/Dewar or Dewar Type							
			CFG-PG4 and DWR-x.xG			CFG-PMOD4 and DWR-MOD-xL		CFG-PS4, CFG-PD4, DWR-xxB and DWR-xxD		
			VOLUME			VOLUME		VOLUME		
Dim.	Unit	Tol. ±	1.2L	3L	5L	3L	7L	7.5L	13L	30L
Q	mm (in)	13 (0.5)	229 (9.0)	302 (11.9)	302 (11.9)	229 (9.0)	302 (11.9)	X X	X X	X X
R	mm (in)	10 (0.4)	X X	X X	X X	X X	X X	174 (6.9)	174 (6.9)	155 (6.1)
S	mm (in)	7.6 (0.3)	X X	X X	X X	X X	X X	77 (3.0)	77 (3.0)	60 (2.3)
T	mm (in)	5 (0.2)	X X	X X	X X	X X	X X	10 (0.4)	10 (0.4)	13 (0.5)
Y	mm (in)	13 (0.5)	157 (6.2)	229 (9.0)	229 (9.0)	157 (6.2)	229 (9.0)	224 (8.8)	307 (12.1)	442 (17.4)
Z	mm (in)	5 (0.2)	229 (9.0)	267 (10.5)	419 (16.5)	292 (11.5)	320 (12.6)	452 (17.8)	429 (16.9)	610 (24.0)

GMX Series Coaxial HPGe Detector Product Configuration Guide

GMX Endcap Diameter and Window

The endcap size must be specified by adding the endcap Model (-xx) to the Detector Model (e.g., GMX25-76 or GMX20P4-70).

If this, or any other dimension is critical, please specify at time of order.

Endcap Model (dia. mm)	-70	-76	-83	-95
Endcap Diameter (in)	2.75	3.00	3.25	3.75
Efficiency	0–20%	25–40%	45–55%	60–100%
Thickness of Al Window	1 mm	1 mm	1 mm	1.5 mm
Thickness of CF Window	0.8 mm	0.8 mm	0.8 mm	0.8 mm

Defining the Detector Model

• See ordering information for option compatibility.

Base Model (example)	PopTop or Streamline	Endcap Diameter	Window Option	Preamplifier Option (if required)	High Voltage Option (if required)
GMX10	P4 (PopTop) (Streamline)	-70	-RB	-PL	-SMN
		-76	-A	-HJ	
		-83	-CW		
		-95	-LB-C		
			-XLB-C		

Example Model Numbers

PopTop Configuration

GMX10P4-70-CW	10% efficiency GMX detector with 70-mm diameter endcap and carbon fiber window.
CFG-PH4	Horizontal Dipstick type cryostat.
MOBIUS-PT	Möbius Recycler.
GMX35P4-76-CW-SMN	35% efficiency GMX detector with 76-mm diameter endcap, carbon fiber window, and SMART-1 preamplifier and high voltage supply.
CFG-PD4-7.5	Downlooking cryostat with 7.5 liter dewar.
GMX50P4-83-RB-SMN	50% efficiency GMX detector with 83-mm diameter reduced background carbon fiber endcap, and SMART-1 preamplifier and high voltage supply.
CFG-PV4	Vertical “dipstick” style cryostat.
DWR-30	30 liter top port dewar that accepts “dipstick” style cryostats.
GMX70P4-95-CW	70% efficiency GMX detector with 95-mm diameter endcap and carbon fiber window.
CFG-ICS-P4	Integrated Cryocooling System

Streamline Configuration

GMX10-70-CW	10% efficiency GMX detector with 70-mm diameter endcap and carbon fiber window.
CFG-GG-70	Portable Gamma Gage cryostat with matching 70-mm diameter flange.
DWR-1.2G	1.2 liter all-position dewar for Gamma Gage cryostat.
GMX35-76-A-SMN	35% efficiency GMX detector with 76-mm diameter endcap, Al window, and SMART-1 preamplifier and high voltage supply.
CFG-SD-76	Downlooking cryostat with matching 76-mm diameter flange.
DWR-7.5D	7.5 liter downlooking dewar for downlooking cryostat.
GMX50-83-CW-HJ	50% efficiency GMX detector with 83-mm diameter endcap, carbon fiber window and remote preamplifier and high voltage filter.
CFG-HJ-83	“J” configuration cryostat with remote fittings for the preamplifier and high voltage filter.
DWR-30B	30 liter side port dewar for “HJ” cryostat.
GMX70-95-LB-C-PL	70% efficiency GMX detector with 95-mm diameter low background carbon fiber endcap, and Plus preamplifier.
CFG-SV-LB-95	Vertical “dipstick” style cryostat with matching 95-mm flange and low background charcoal pumping agent.
DWR-30 30	liter top port dewar that accepts “dipstick” style cryostats.

GMX Series Coaxial HPGe Detector

Product Configuration Guide

Ordering Information and Warranted Specifications

- Endcap Diameter must be specified. See Defining the Detector Model and Example Models on page 14.
- Cryostat and dewar or other cooling device are not included with detector.
- Cryostat and dewar or other cooling device are required for operation.
- A cryostat must be ordered with a Streamline detector.
- Monte Carlo drawings and certified factory test results are included.

Base Model No.	Relative Photopeak Efficiency % (Minimum)	Resolution			Peak-to-Compton Ratio (Minimum)	Peak Shape		Endcap Diameter (mm) Nominal
		@ 5.9 keV (keV FWHM) (Typical)	@122 keV (keV FWHM) (Maximum)	@1.33 MeV (keV FWHM) (Maximum)		FW.1M/ FWHM (Maximum)	FW.02M/ FWHM (Typical)	
GMX10	10	0.60	0.85	1.8	40:1	1.9	2.6	-70
GMX15	15	0.64	0.88	1.9	44:1	1.9	2.6	-70
GMX20	20	0.65	0.88	1.9	48:1	1.9	2.8	-70
GMX25	25	0.69	0.90	1.9	48:1	1.9	2.8	-76
GMX30	30	0.72	0.90	1.9	52:1	1.9	2.8	-76
GMX35	35	0.73	1.00	2.0	55:1	2.0	3.0	-76
GMX40	40	0.76	1.00	2.0	59:1	2.0	3.0	-76
GMX45	45	0.80	1.10	2.1	60:1	2.0	3.0	-83
GMX50	50	0.80	1.10	2.2	58:1	2.0	3.0	-83
GMX60	60	1.10	1.30	2.3	56:1	2.0	3.0	-95
GMX70	70	1.10	1.30	2.3	60:1	2.0	3.0	-95
GMX80	80	1.10	1.30	2.3	63:1	2.0	3.0	-95
GMX90	90	1.20	1.40	2.4	64:1	2.1	3.1	-95
GMX100	100	1.20	1.40	2.5	64:1	2.2	3.2	-95

Notes:

- 1) FWHM = Full Width at Half Maximum; FW.1M = Full Width at One-Tenth Maximum; FW.02M = Full Width at One-Fiftieth Maximum; total system resolution measured at the factory in accordance with ANSI/IEEE Std. 325-1996.
- 2) Measured at optimal shaping time using an ORTEC DSPEC-50A.

GAMMA-X Detector Options

- Append suffix to base model number. See Defining the Detector Model and Example Models on page 14.

Suffix	Description
P4	<u>PopTop Only.</u> PopTop capsule, add "P4" to the model number.
-RB	<u>PopTop Only.</u> Reduced background PopTop capsule with Carbon Fiber endcap, add "-RB" to the model number.
-LB-C	<u>Streamline Only.</u> Low-Background Detector with Carbon Fiber Endcap, add "-LB-C" to the model number. Requires selection of a Low-Background LB cryostat.
-XLB-C	<u>Streamline Only.</u> Extra-Low-Background Detector with Carbon Fiber Endcap, add "-XLB-C" to the model number. Requires selection of a Low-Background XLB cryostat.
-A	Aluminum endcap at no extra charge, add "-A" to the model number.
-CW	Carbon Fiber Window (0.8 mm thick) at no extra charge, add "-CW" to the model number.
-HJ	<u>Streamline Only.</u> Remote preamplifier and high voltage filter for use with HJ type cryostat, add "-HJ" to the model number. Requires selection of HJ cryostat. Not compatible with -PL or -SMN options.
-PL	PLUS Ultra-high-count-rate Preamplifier, add "-PL" to the model number. Not compatible with -HJ option.
-SMN	SMART-1 detector option for negative bias detector, add "-SMN" to the model number. Not compatible with -HJ option.

GMX Series Coaxial HPGe Detector Product Configuration Guide

GAMMA-X PopTop Cryostats and Dewars

Model No.	Description
CFG-MG4-1.2G	Gamma Gage Cryostat with 1.2-liter Dewar, Pistol Grip handle and mounting holes to fit the M-1-T1 Tripod (for 83 mm or smaller endcaps)
CFG-PD4-7.5	Down-looking Cryostat with 7.5-liter Dewar
CFG-PD4-13	Down-looking Cryostat with 13-liter Dewar
CFG-PD4-30	Down-looking Cryostat with 30-liter Dewar
CFG-PG4-1.2	Gamma Gage Cryostat with 1.2-liter Dewar (for 83 mm or smaller endcaps)
CFG-PG4-3	Gamma Gage Cryostat with 3-liter Dewar
CFG-PG4-5	Gamma Gage Cryostat with 5-liter Dewar
CFG-PH4	Horizontal Cryostat (Dipstick type). Choose DWR-30, DWR-30-OP, MOBIUS-PT or MOBIUS-PT-DET.
CFG-PMOD4-3	Gamma Gage Cryostat with 3-liter Multi-Orientation Dewar
CFG-PMOD4-7	Gamma Gage Cryostat with 7-liter Multi-Orientation Dewar
CFG-PS4-7.5	Side-Looking Cryostat with 7.5-liter Dewar
CFG-PS4-13	Side-Looking Cryostat with 13-liter Dewar
CFG-PS4-30	Side-Looking Cryostat with 30-liter Dewar
CFG-PS4-MOBIUS-B	Side-Looking Cryostat with Möbius Recycler 28-liter Dewar
CFG-PS4-MOBIUS-B-DET	Side-Looking Cryostat with Möbius Recycler 28-liter Dewar for purchase in combination with any PopTop detector.
CFG-PSHP4	Down-Looking Shallow-Hole Probe with 0.7-liter Dewar
CFG-PV4	Vertical Cryostat (Dipstick type). Choose DWR-30, DWR-30-OP, MOBIUS-PT or MOBIUS-PT-DET.
CFG-ICS-P4	Integrated Cryocooling System
MOBIUS-PT	Möbius Recycler.
MOBIUS-PT-DET	Möbius Recycler Dewar for purchase in combination with any PopTop detector and vertical or horizontal dipstick cryostat.
DWR-30	30-liter Dewar. Includes collar for 1.5" diameter cryostat.
DWR-30-OP	30-liter Offset-Port Dewar. Includes collar for 1.5" diameter cryostat.
DWR-S/F	Storage Fill Dewar for CFG-PG4-X

GMX Series Coaxial HPGe Detector Product Configuration Guide

GAMMA-X Streamline Cryostats

- May only be purchased with a detector.
- Append matching Detector Endcap Size designation to cryostat model: -70, -76, -83, -95 [e.g., CFG-SJ-95 for GMX70-95, or CFG-SL-XLB-76 for GMX25-76-XLB-C]
- Dewar required. Select dewar from GAMMA-X Streamline Dewars.
- Horizontal and Vertical Cryostats include CFG-ADAPTOR to increase cryostat diameter from 1.25 inch to 1.5 inch for use with DWR-30 and DWR-30-OP.

Model No.	Description
CFG-GG	Gamma Gage Cryostat
CFG-HJ	J-type Cryostat with Remote Preamp. (for -HJ option only)
CFG-SD	Down-Looking Cryostat
CFG-SH	Horizontal Cryostat (Dipstick type).
CFG-N-SH	Horizontal Cryostat with vacuum valve (Dipstick type). Requires model VV02 and model 496-1 (110 V/60 Hz) or model 496-2 (220 V/50 Hz)
CFG-SJ	J-type Cryostat
CFG-SL	Side-Looking Cryostat
CFG-SV	Vertical Cryostat (Dipstick type).

LOW-BACKGROUND

CFG-GG-LB	Low-Background Gamma Gage Cryostat
CFG-HJ-LB	Low-Background J-type Cryostat with Remote Preamp. (for -HJ option only)
CFG-SD-LB	Low-Background Down-Looking Cryostat
CFG-SH-LB	Low-Background Horizontal Cryostat (Dipstick type).
CFG-SJ-LB	Low-Background J-type Cryostat
CFG-SL-LB	Low-Background Side-Looking Cryostat
CFG-SV-LB	Low-Background Vertical Cryostat (Dipstick type).
CFG-SD-XLB	Extra-Low-Background Down-Looking Cryostat
CFG-SH-XLB	Extra-Low-Background Horizontal Cryostat (Dipstick type).
CFG-SJ-XLB	Extra-Low-Background J-type Cryostat
CFG-SL-XLB	Extra-Low-Background Side-Looking Cryostat
CFG-SV-XLB	Extra-Low-Background Vertical Cryostat (Dipstick type).

PROFILE Streamline Dewars

For Cryostat	Choose	Description
CFG-GG	DWR-1.2G	1.2-liter All-Orientation Dewar
	DWR-3.0G	3.0-liter All-Orientation Dewar
	DWR-5.0G	5.0-liter All-Orientation Dewar
	DWR-MOD-3L	3-liter Multi-Orientation Dewar
	DWR-MOD-7L	7-liter Multi-Orientation Dewar
	DWR-0.7-SHP-G	0.7-liter Shallow-Hole Probe Dewar
	DWR-S/F	Storage/Fill Dewar for DWR-XG
CFG-HJ, SJ, SL	DWR-7.5B	7.5-liter Side-Looking Dewar
	DWR-13B	13-liter Side-Looking Dewar
	DWR-30B	30-liter Side-Looking Dewar
	MOBIUS-B	Möbius Recycler Side-Looking Dewar
CFG-SD	DWR-7.5D	7.5-liter Down-Looking Dewar
	DWR-13D	13-liter Down-Looking Dewar
	DWR-30D	30-liter Down-Looking Dewar
CFG-SV, SH, N-SH	DWR-30	30-liter Dewar. Includes collar for 1.5" diameter cryostat.
	DWR-30-OP	30-liter Offset-Port Dewar. Includes collar for 1.5" diameter cryostat.
	MOBIUS-ST	Möbius Recycler Dewar for purchase stand alone
	MOBIUS-ST-DET	Möbius Recycler Dewar for purchase in combination with Detector



www.ortec-online.com

Tel. (865) 482-4411 ortec.info@ametek.com

801 South Illinois Avenue, Oak Ridge, TN 37830 U.S.A.

Visit Our Website For International Office Locations

Specifications subject to change
25-0225