

P-type Coaxial HPGe Detectors for High Performance Gamma Spectroscopy in the Energy Range of ~40 keV and Up.

The majority of gamma spectroscopy applications such as those found in counting laboratories involve the energy range ~40 keV upward. ORTEC GEM detectors are designed to cover this energy range.

All GEM Series feature:

- Efficiencies to 150%, higher on request.
- Excellent energy resolution and peak symmetry.
- SMART bias options.
- Low-background carbon fiber endcap options.
- PLUS preamplifier option for ultra-high-rate applications.
- Configuration flexibility: PopTop, Streamline and mechanically cooled options.

ORTEC offers GEM Series HPGe detectors with relative efficiencies¹ from 10% to 150% and beyond. The detectors are manufactured from ORTEC-grown germanium crystals processed in our advanced manufacturing facility in Oak Ridge, TN. The detectors are fabricated from P-type germanium with an outer contact of diffused Li and an inner contact of ion-implanted boron.

ORTEC maintains a stocklist of GEM detectors. Some of these have “super specifications,” that is energy resolution and/or efficiency better than the usual GEM warranted specifications.

The Following Data are Provided with each GEM Detector

- Measured energy resolution full-width half-maximum (FWHM) at 1.33-MeV.
- Measured relative photopeak efficiency at 1.33 MeV.
- Measured Peak-to-Compton ratio at 1.33 MeV.
- Measured peak shape ratio for the full-width tenth-maximum to the FWHM at 1.33 MeV.
- Measured energy resolution at 122 keV.

Configuration Guidelines

PopTop or Streamline (non-PopTop) Configuration

The essence of a PopTop detector system is that the HPGe detector element, preamplifier, and high voltage filter are housed in a detector “capsule” which is then attached to an appropriate cryostat (Figure 2.)

In Streamline systems, the detector capsule is NOT demountable. Detector capsule and cryostat share the same vacuum. In configuration terms, this requires a cryostat or cryostat/dewar selection with the cryostat having a matching diameter to the capsule endcap or an integrated cryocooling system (ICS). A cryostat or ICS must always be ordered with a Streamline capsule, because they are integral.

The actual PopTop capsule has its own vacuum. It can be mounted on any of the available cryostats, cryostat/dewar combinations, or ICS-P4 mechanical cooling system.

Certain cryostat configurations are available only as PopTop and others are available only as Streamline.

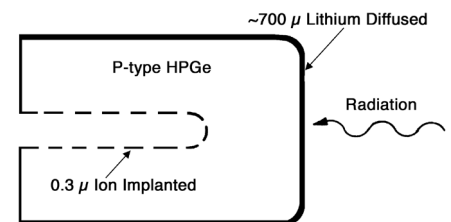

Fig. 1. Configuration of GEM Coaxial Germanium Crystal.

¹By convention, HPGe detectors are characterized by “relative efficiency”. Relative efficiency is defined as the efficiency of a point Co-60 source at 25 cm from the face of a standard 3-inch x 3-inch right circular cylinder NaI(Tl) detector. “IEEE Test Procedures for Germanium Detectors for Ionizing Radiation,” ANSI/IEEE Standard 325-1986.

GEM Series Coaxial HPGe Detector Product Configuration Guide

Steps to Configure Your ORTEC HPGe Detector

1) Configure the Detector Model

- Capsule type (PopTop or Streamline)
- Ge Crystal efficiency and specifications
- Endcap and window
- Mount
- Preamplifier
- High Voltage Filter
- Cable Package
- Integrated Cryocooling System (ICS)

Options are available for the detector model that can change specific materials used in the construction of the detector endcap, cup, and mount. Preamplifier options are also available.

2) Configure the Cryostat/Dewar or ICS Model

- Vertical Dipstick style (separate Dewar or Mobius Recycler)
- Horizontal Dipstick style (separate Dewar or Mobius Recycler)
- Portable with all-position or multi-position cryostat/dewar models
- Downlooking designed to be oriented with the detector pointing down
- Sideloooking designed to be oriented with the detector horizontal at the bottom of the dewar
- "J" configurations designed with the detector attached near the bottom of the dewar and a right angle bend in the cryostat orienting the detector to look up.

A cryostat and dewar or other cooling device are required for operation.

If a PopTop detector has been selected, you can choose a PopTop style cryostat, cryostat/dewar combination or ICS-P4 mechanical cooling systems.

If a Streamline detector has been selected, you must choose a cryostat or cryostat/dewar model for the detector to be mounted on and vacuum sealed or an ICS. The cryostat, cryostat/dewar combination or ICS diameter must match the endcap diameter of the selected detector.

Detector Options

Integrated Cryocooling System Option (-ICS-E, -ICS-HJ)

Integrated Cryocooling System (ICS) cryostats are sealed with a cryocooler and immune to thermal short cycling. Unlike the typical three day loss of use of the detector with a standard type cryostat, an ICS can be re-cooled immediately, minimizing any time lost for temporary warm up.

Integrated Cryocooling Low-Background System (-ICS-LB-HJ)

Low-background detector, high purity aluminum endcap, high purity aluminum window, high purity aluminum internal cup, and low-background Cu mount for the ICS Integrated Cryocooling System. The lower background material allows for lower Minimum Detectable Activity (MDA) for a specific counting time, which provides another step in increasing sample throughput in low-background applications.

SMART-1 Option (-SMP)

The SMART-1 option monitors and reports on vital system functions, and can save authentication codes and report the code at a later time. It has the high voltage included, so none of the instruments require an external high-voltage power supply.

The SMART-1 is housed in a rugged ABS molded plastic enclosure and is permanently attached to the detector endcap via a molded-strain-relieved sealed cable. This eliminates the possibility that the detector will suffer severe damage from moisture leaking into high-voltage connectors. The SMART-1 can be positioned in any convenient place and does not interfere with shielding or other mounting hardware.

Ultra-High Count-Rate Preamplifier Option (-PL)

The Ultra-High Count-Rate Preamplifier (transistor-reset preamplifier) can handle input count rates up to 1,000,000 counts/s at 1 MeV, and offers the added benefit of having no feedback resistor.

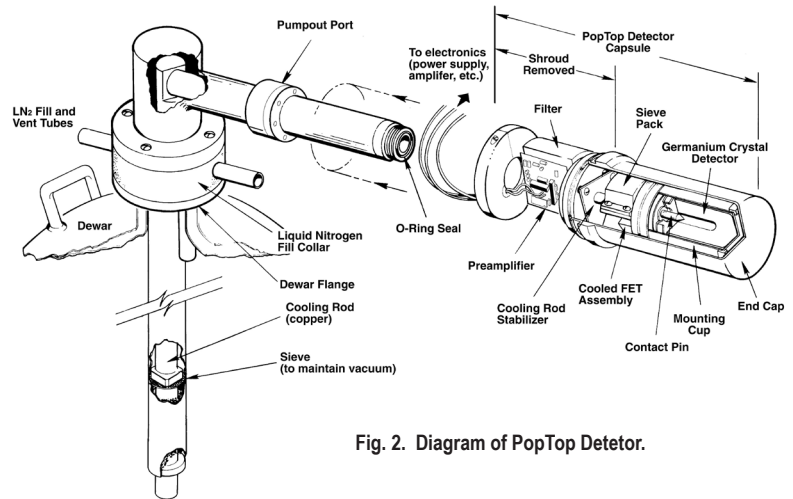

Fig. 2. Diagram of PopTop Detetor.

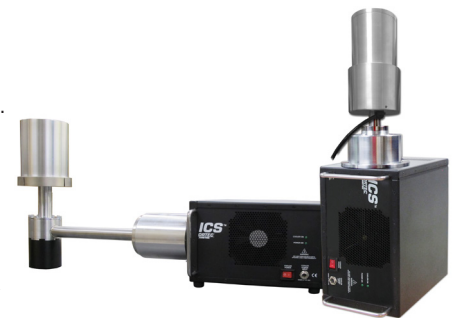

Fig. 3. ICS Integrated Cryocooling Systems.



Fig. 4. SMART-1 Detector Interface Module.

GEM Series Coaxial HPGe Detector Product Configuration Guide

Remote Preamplifier Option (-HJ, ICS-HJ)

This option allows all the preamplifier and high voltage connections to be outside a shield and removes the preamplifier and high voltage filter from the "line-of-sight" to the Ge crystal. For low background applications, this option eliminates any possible preamplifier or high voltage filter components that may add to the background inside a shield.

Low-Background Carbon Fiber Endcap Options (-RB, -LB-C, and -XLB-C)

Carbon Fiber is as strong as Al, Mg, and Cu, creates less background and does not corrode.

This lower background material allows for lower Minimum Detectable Activity (MDA) for a specific counting time, which provides another step in increasing sample throughput in low-background counting applications. The lower Z of Carbon Fiber provides a low-energy window without the additional background found in most alloys. See Table 1 for transmission characteristics of the aluminum and carbon fiber windows.

Carbon Fiber, unlike Beryllium, is non-toxic and can be cleaned with most laboratory solvents such as methanol, trichloroethylene, and acetone. Soap and water may also be used. Abrasive cleaners should not be used.

Energy (keV)	Aluminum Window % Transmission	Carbon Fiber Window % Transmission
3	0	0.29
5	0	23
10	0.09	82
20	40	97
30	74	99
50	91	100
80	95	100
100	96	100
400	97	100
1000	98	100

GEM Series Coaxial HPGe Detector Product Configuration Guide

PopTop Detector Capsule

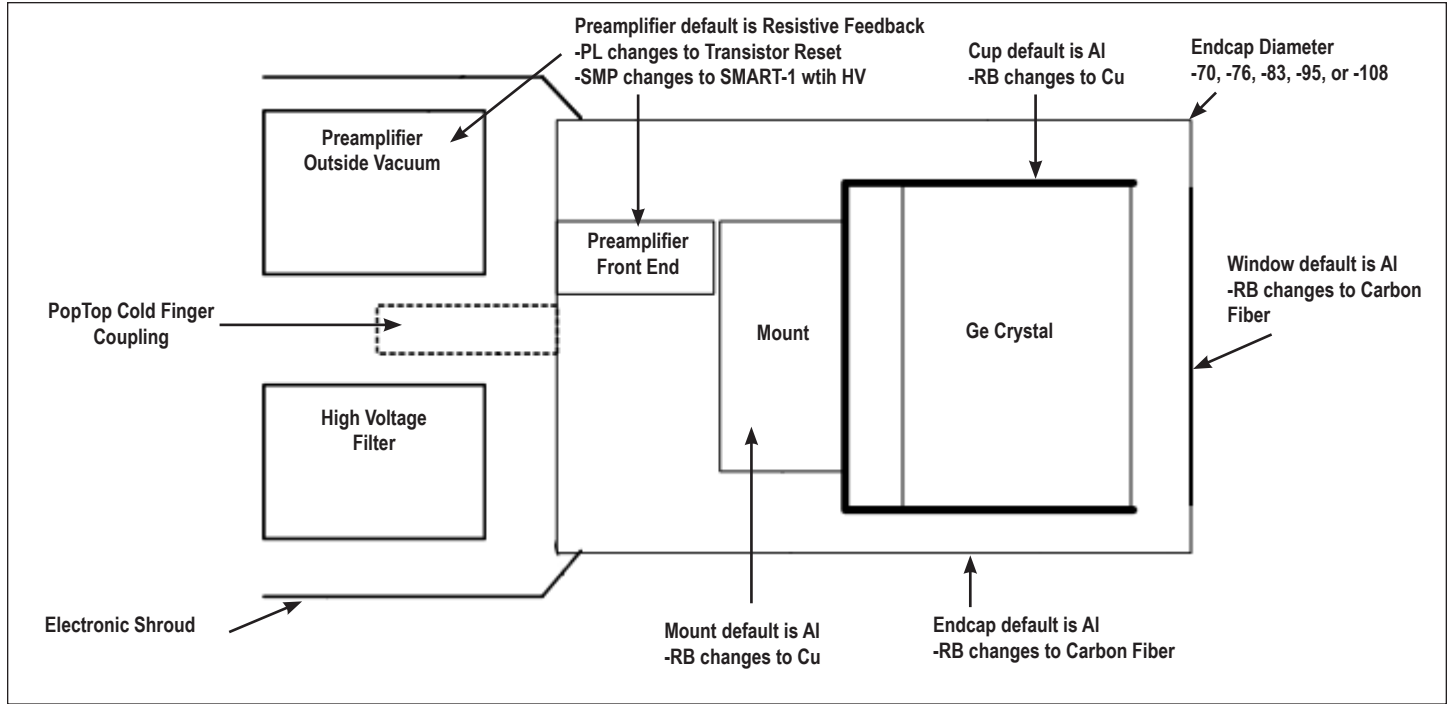

Streamline Detector Capsule

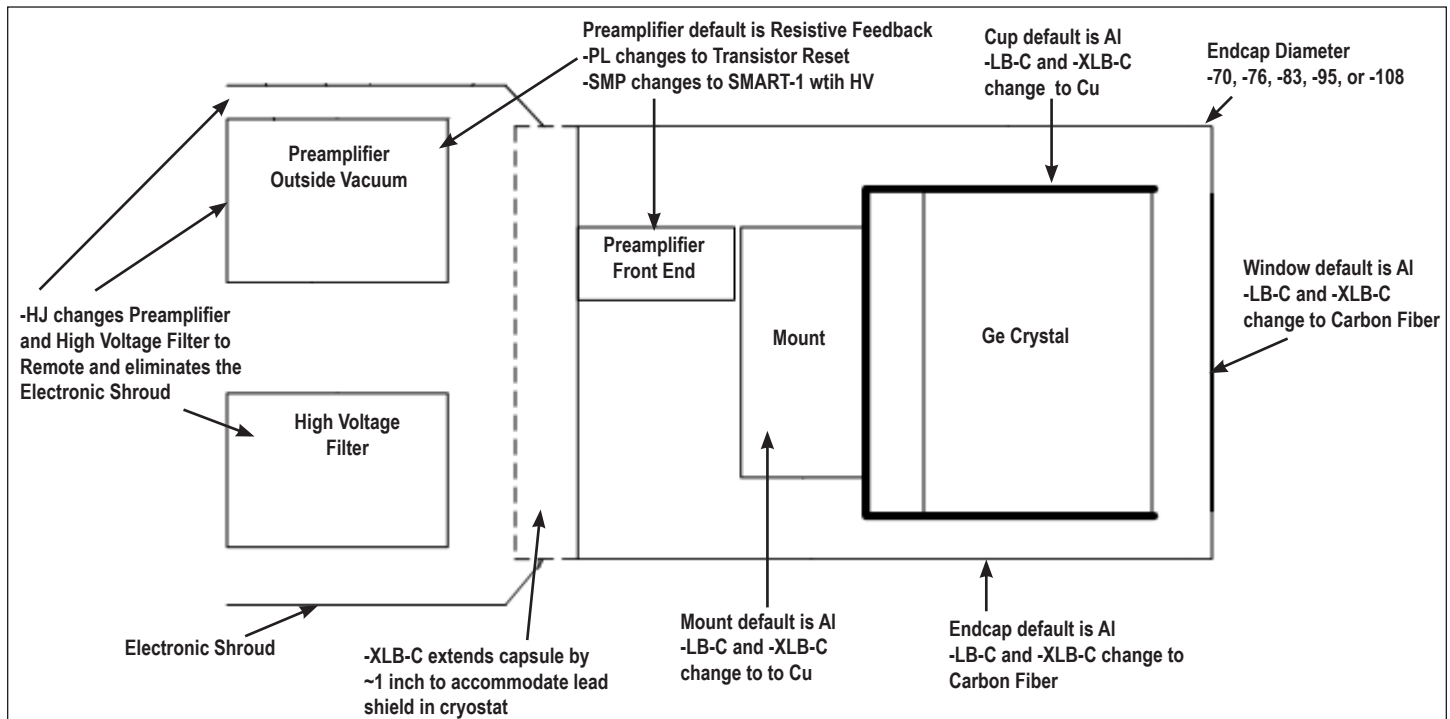

GEM Series Coaxial HPGe Detector Product Configuration Guide

Streamline Detector Capsule for Integrated Cryocooling System with External Preamp (ICS-E)

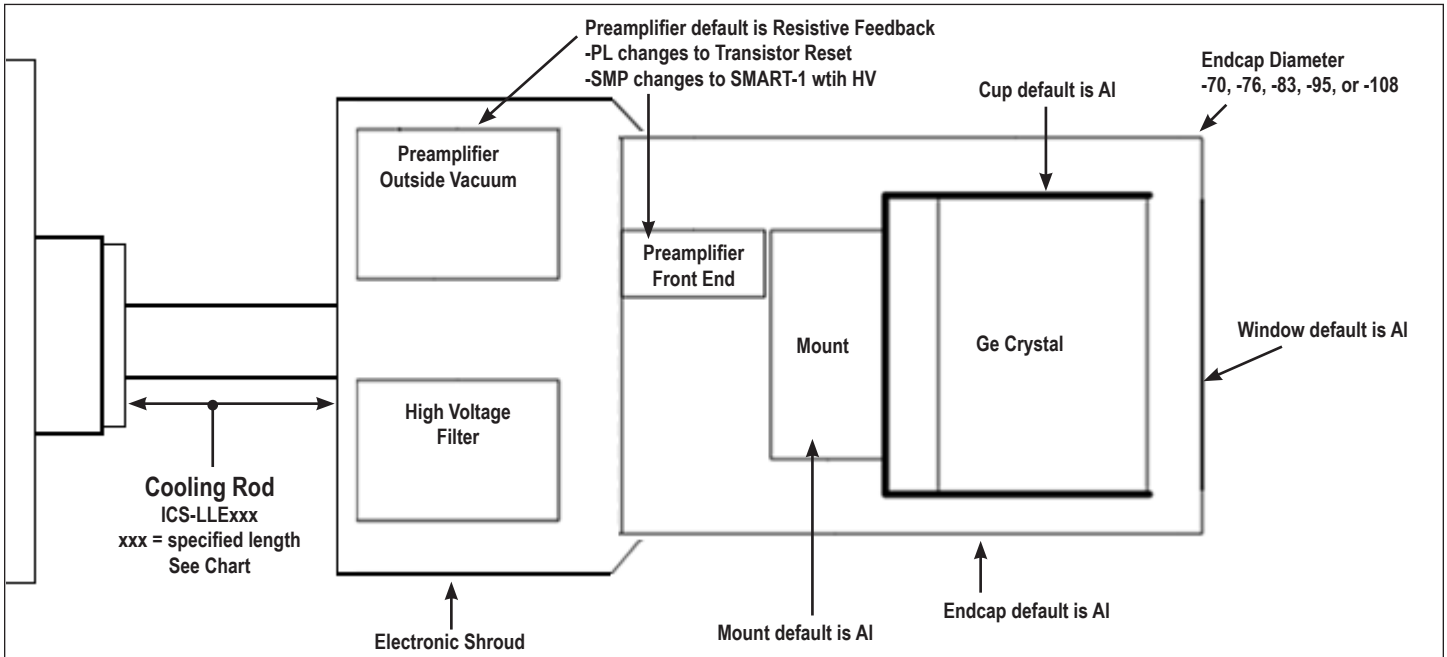

Streamline Detector Capsule for Integrated Cryocooling System with Remote Preamp (ICS-HJ)

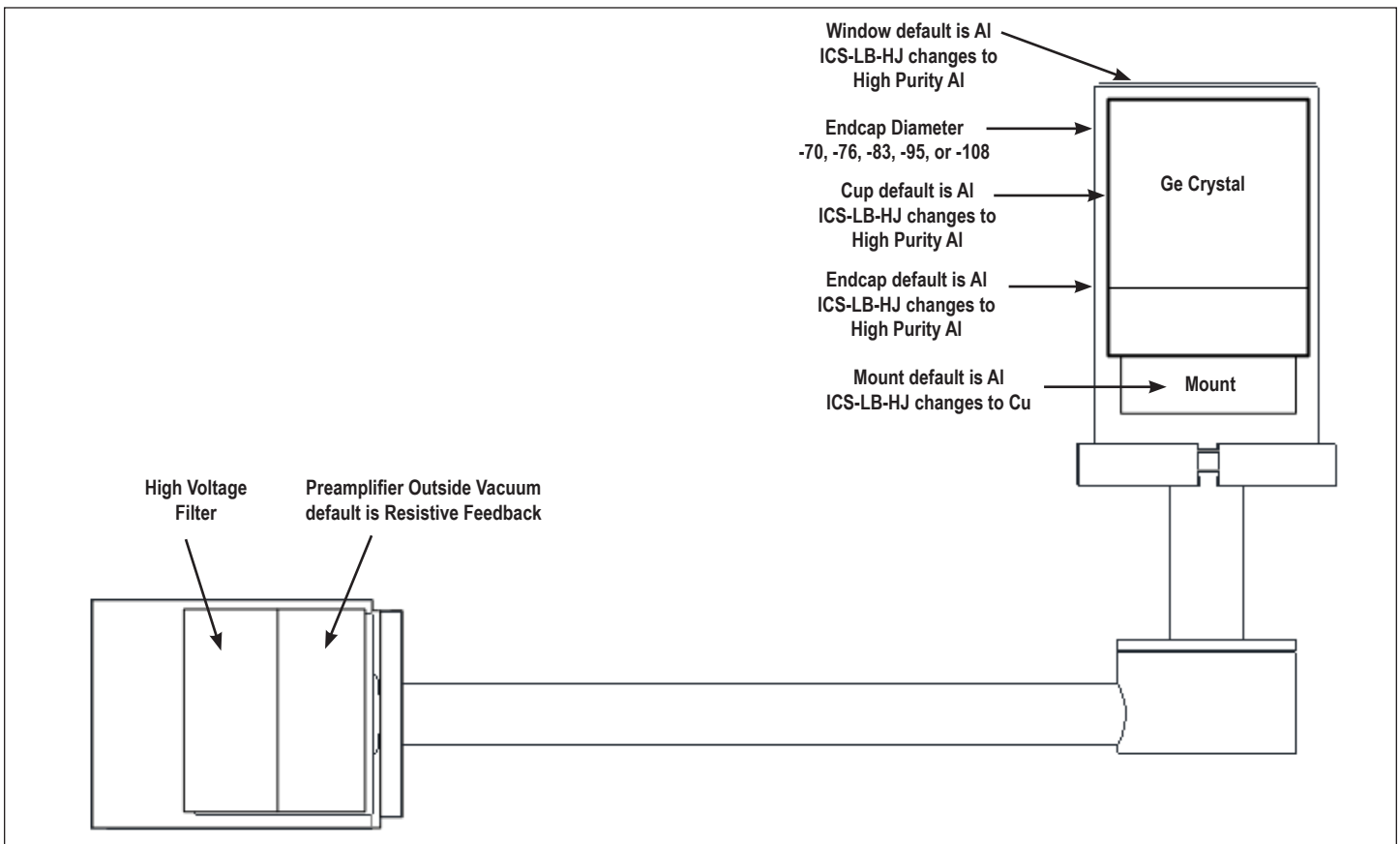

GEM Series Coaxial HPGe Detector Product Configuration Guide

Streamline Cryostat and Cryostat/Dewar Assemblies

Streamline systems (detector capsule and cryostat) share the same vacuum, requiring a cryostat or cryostat/dewar selection with the cryostat having a matching diameter to the capsule endcap.

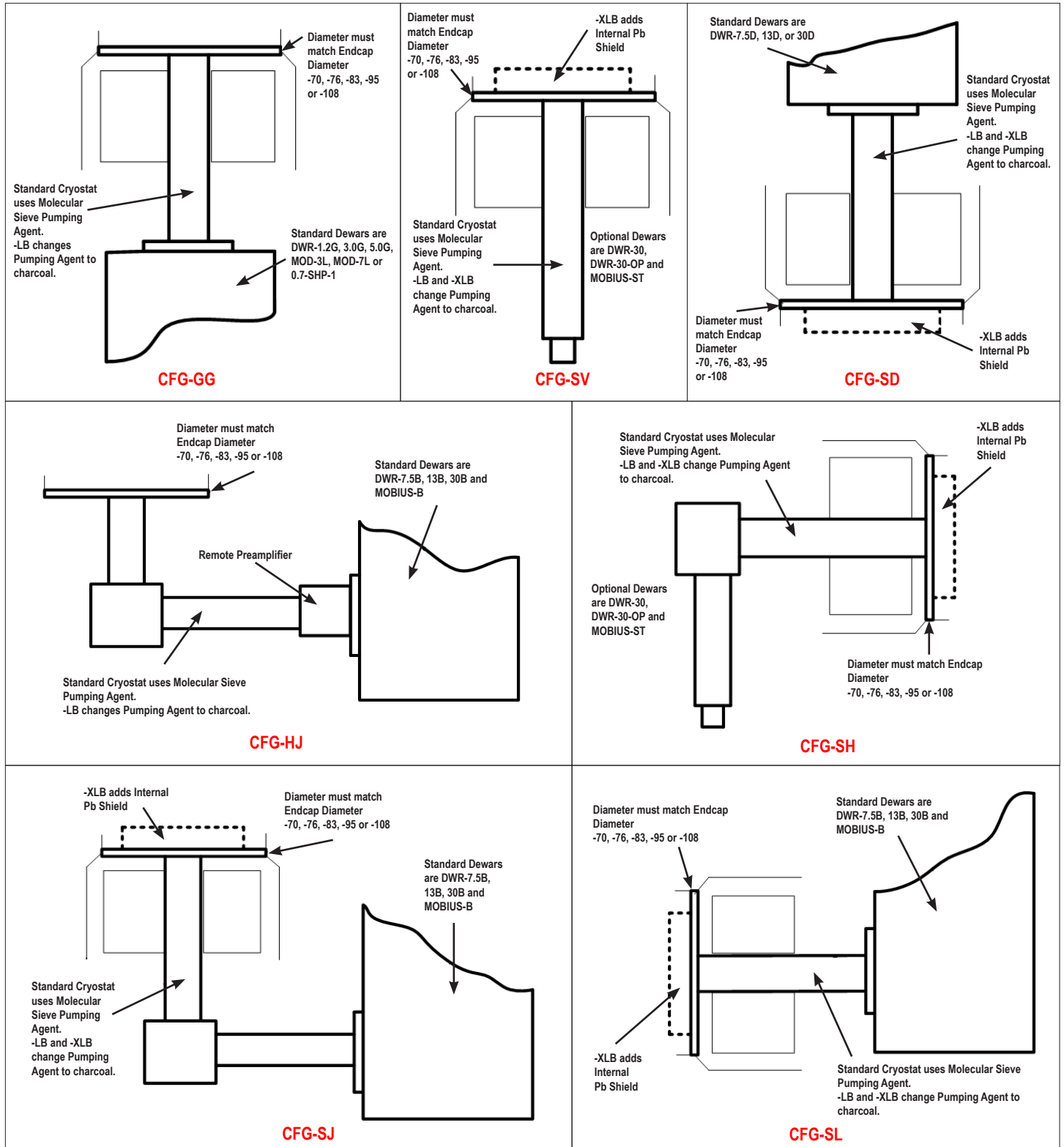

GEM Series Coaxial HPGe Detector Product Configuration Guide

PopTop and Streamline Dimensional Data

Streamline systems (detector capsule and cryostat or ICS) share the same vacuum. A cryostat or ICS must be ordered with a Streamline capsule. The cryostat or cryostat/dewar selection must have a matching diameter to the capsule endcap.

The PopTop capsule features an internal vacuum arrangement. It can be mounted on any of the available PopTop cryostats, cryostat/dewar combinations, or ICS-P4 mechanical cooling systems.

The cryostat and dewar drawings that follow are to be used in conjunction with the accompanying tables of dimensions.

Note: Cryostat/Dewar drawings are NOT to scale, see tables that follow for complete dimensions. Dimensions are for reference only and subject to change, if dimensional constraints are critical, contact the factory.

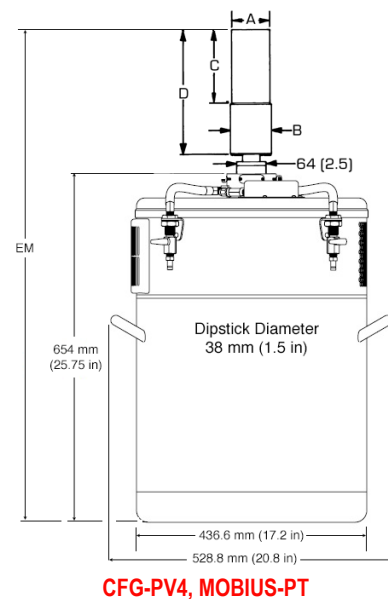
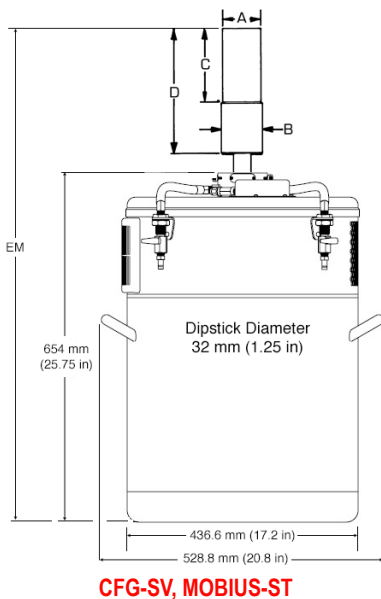
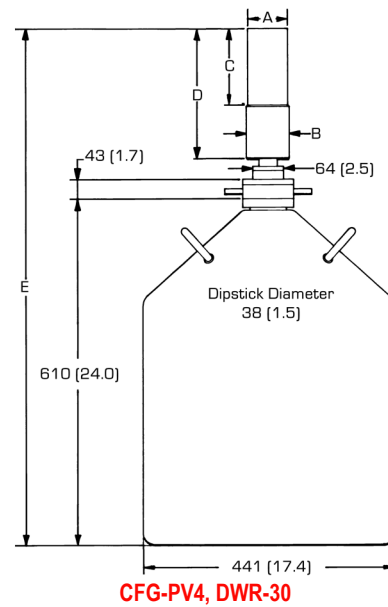
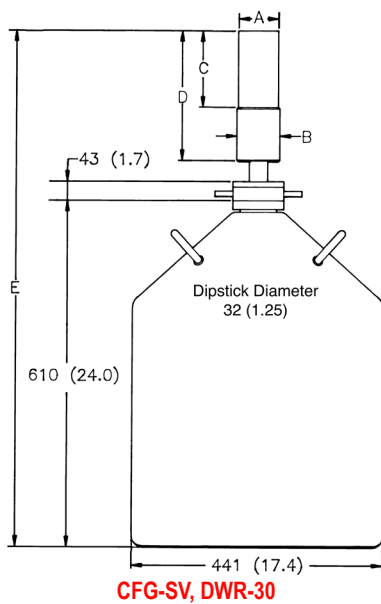

GEM Series Coaxial HPGe Detector Product Configuration Guide

Note: Cryostat/Dewar drawings are NOT to scale, see tables that follow for complete dimensions. Dimensions are for reference only and subject to change, if dimensional constraints are critical, contact the factory.

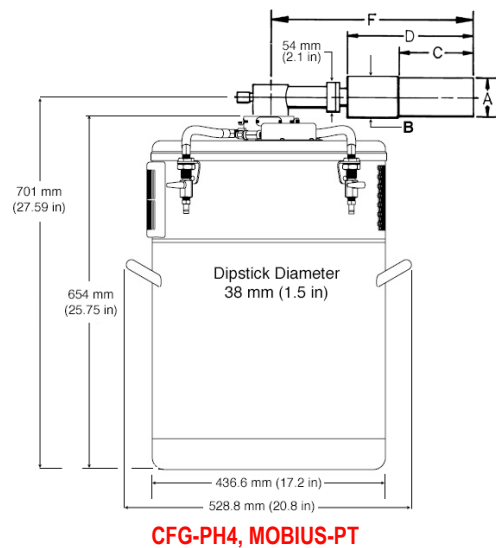
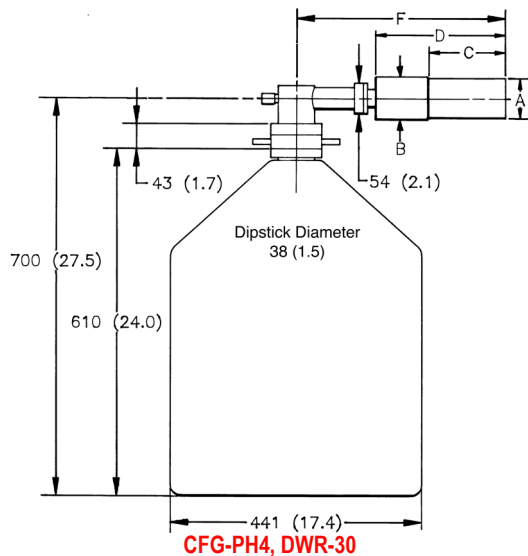
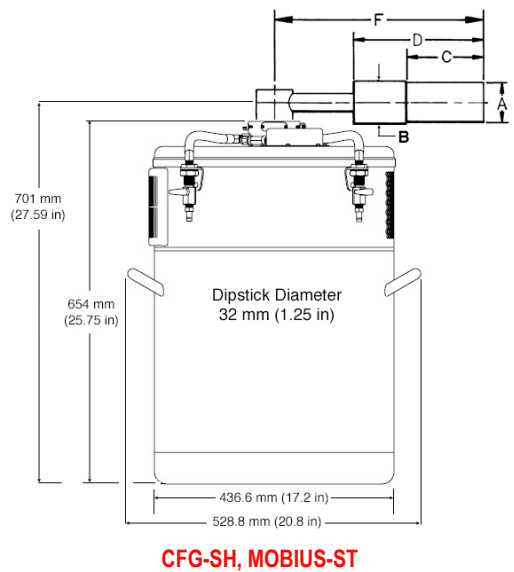
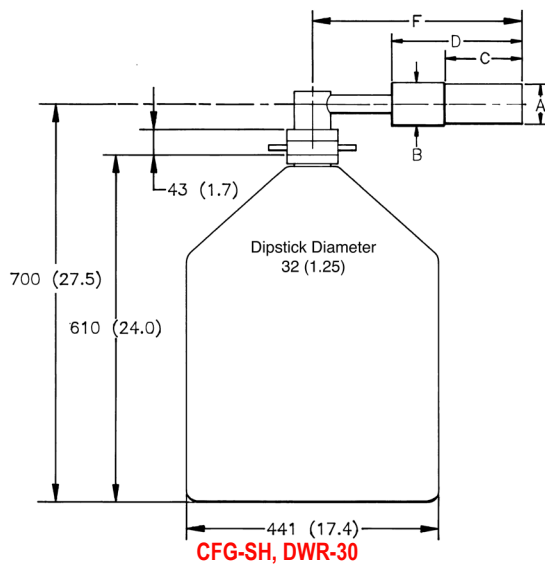

GEM Series Coaxial HPGe Detector Product Configuration Guide

Note: Cryostat/Dewar drawings are NOT to scale, see tables that follow for complete dimensions. Dimensions are for reference only and subject to change, if dimensional constraints are critical, contact the factory.

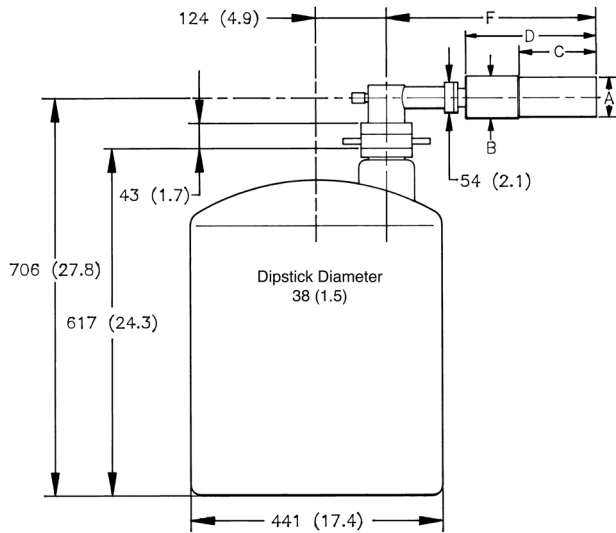

CFG-PH4, DWR-30-OP

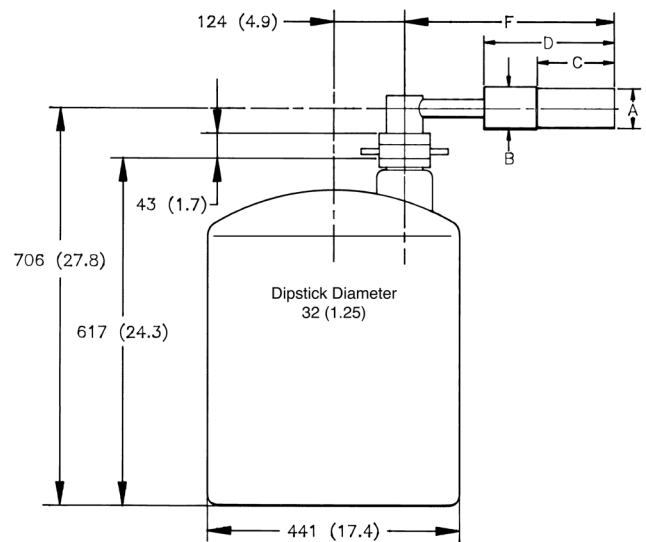

CFG-SH, DWR-30-OP

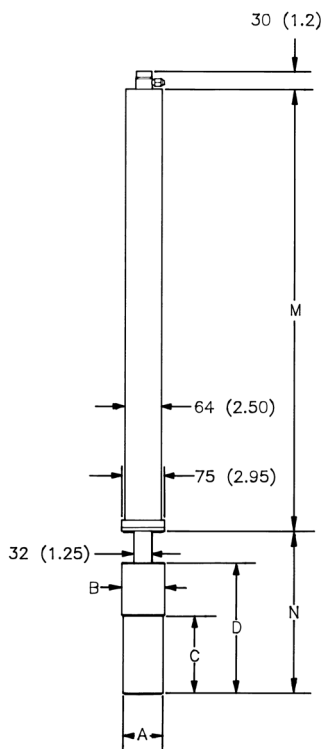

**CFG-PSHP4 or
CFG-GG, DWR-0.7-SHP-1**

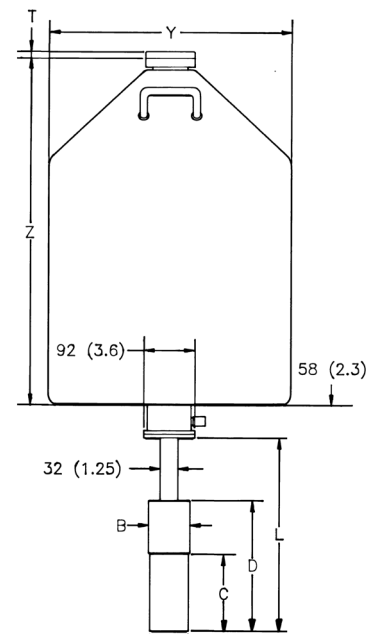

**CFG-PD4-30 (or -13 or -7.5) or
CFG-SD, DWR-30D (or -13D or -7.5D)**

GEM Series Coaxial HPGe Detector Product Configuration Guide

**Note: Cryostat/Dewar drawings are NOT to scale, see tables that follow for complete dimensions.
Dimensions are for reference only and subject to change, if dimensional constraints are critical, contact the factory.**

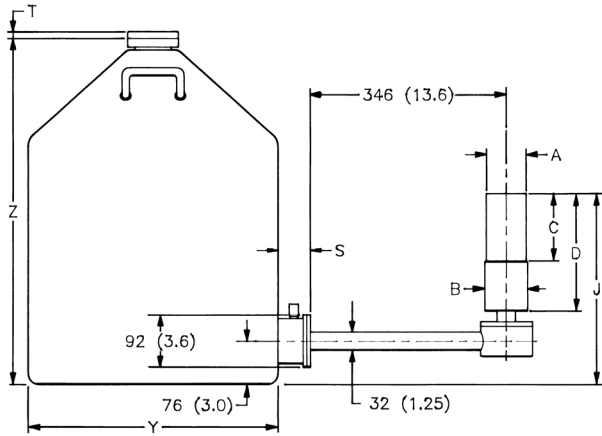

CFG-SJ, DWR-30B (or -13B or -7.5B)

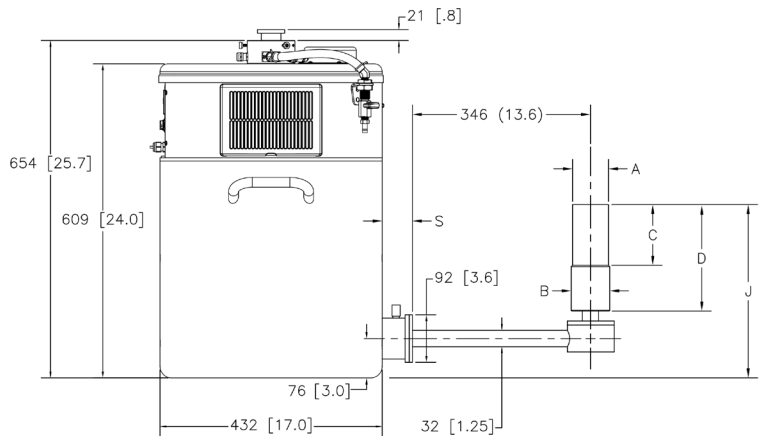

CFG-SJ, MOBIUS-B

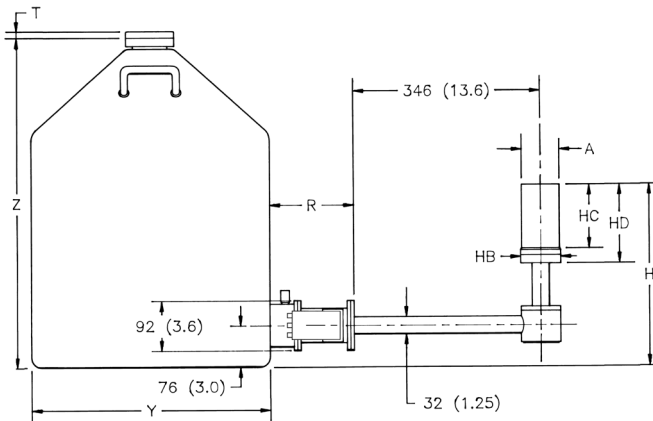

CFG-HJ, DWR-30B (or -13B or -7.5B)

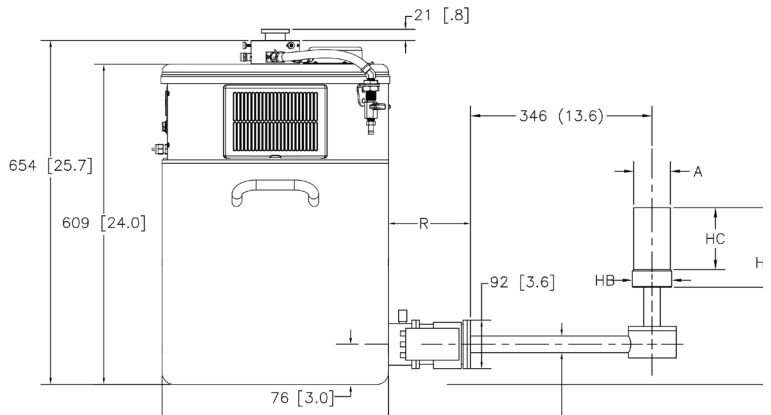

CFG-HJ, MOBIUS-B

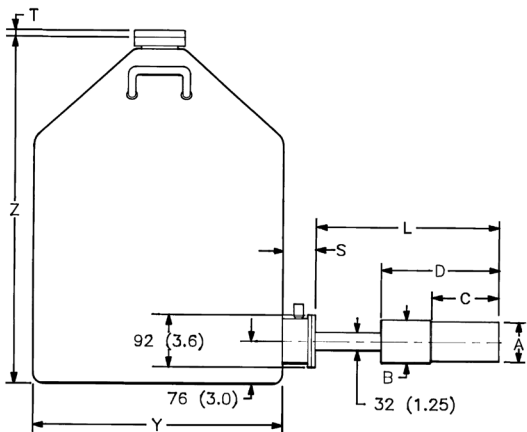

**CFG-PS4-30 (or -13 or -7.5) or
CFG-SL, DWR-30B (or -13B or -7.5B)**

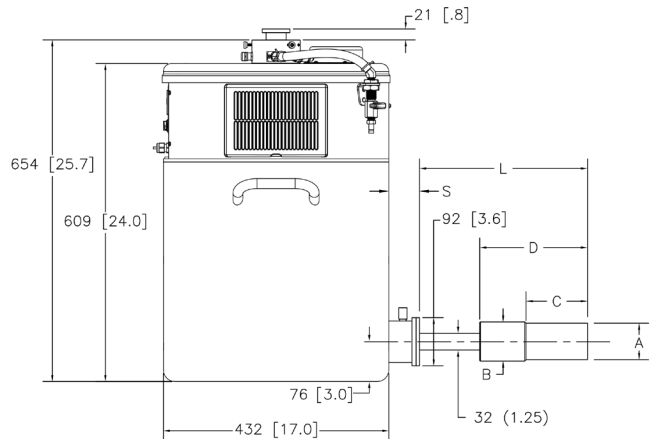

CFG-PS4-MOBIUS-B or CFG-SL, MOBIUS-B

GEM Series Coaxial HPGe Detector Product Configuration Guide

Note: Cryostat/Dewar drawings are NOT to scale, see tables that follow for complete dimensions.
Dimensions are for reference only and subject to change, if dimensional constraints are critical, contact the factory.

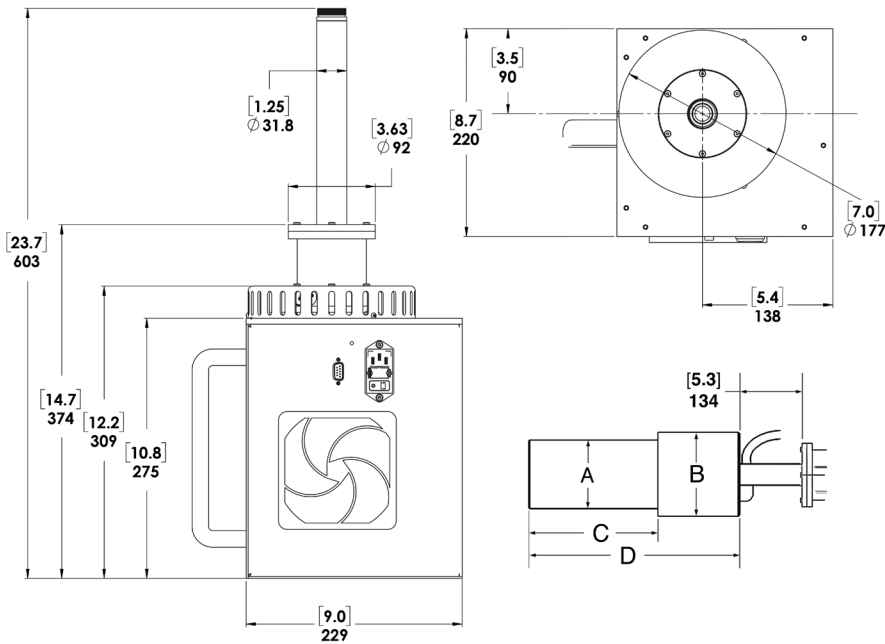

CFG-ICS-P4

PopTop GEM Detector Dimensions

- Dimensions are for reference only and subject to change.
- If dimensional constraints are critical, contact the factory.

Endcap Model (dia. mm)			-70	-76	-83	-95	-108
% Efficiencies available in this endcap size			0-20	25-40	45-55	60-110	120-150
Dim.	Unit	Tol.					
A	mm (in)	0.3 (0.01)	70 (2.75)	76 (3.0)	83 (3.25)	95 (3.75)	108 (4.25)
B	mm (in)	0.3 (0.01)	75 (2.95)	88 (3.45)	88 (3.45)	100 (3.95)	113 (4.45)
C	mm (in)	5 (0.2)	134 (5.3)	165 (6.4)	168 (6.6)	193 (7.6)	207 (8.2)
D	mm (in)	8 (0.3)	250 (9.8)	282 (11.2)	282 (11.2)	309 (12.2)	323 (12.7)
E	mm (in)	18 (0.7)	947 (37.3)	982 (38.6)	982 (38.6)	1007 (39.7)	1019 (40.1)
EM	mm (in)	19 (0.75)	948 (37.3)	983 (38.7)	983 (38.7)	1008 (39.7)	1020 (40.1)
F	mm (in)	10 (0.4)	396 (15.6)	429 (16.9)	429 (16.9)	455 (17.9)	469 (18.5)
L	mm (in)	10 (0.4)	338 (13.3)	371 (14.6)	371 (14.6)	396 (15.6)	412 (16.2)
M	mm (in)	8 (0.3)	790 (31.1)	X X	X X	X X	X X
N	mm (in)	10 (0.4)	278 (10.9)	312 (12.3)	312 (12.3)	338 (13.3)	348 (13.7)

GEM Series Coaxial HPGe Detector

Product Configuration Guide

Streamline GEM Detector Dimensions

- Dimensions are for reference only and subject to change.
- If dimensional constraints are critical, contact the factory.

Endcap Model (dia. mm)			Standard or LB					XLB				
Endcap Model (dia. mm)			-70	-76	-83	-95	-108	-70	-76	-83	-95	-108
% Efficiencies available in this endcap size			0–20	25–40	45–55	60–110	120–150	0–20	25–40	45–55	60–110	120–150
Dim.	Unit	Tol.										
A	mm (in)	0.3 (0.01)	70 (2.75)	76 (3.0)	83 (3.25)	95 (3.75)	108 (4.25)	70 (2.75)	76 (3.0)	83 (3.25)	95 (3.75)	108 (4.25)
B	mm (in)	0.3 (0.01)	75 (2.95)	88 (3.45)	88 (3.45)	100 (3.95)	113 (4.45)	75 (2.95)	88 (3.45)	88 (3.45)	100 (3.95)	113 (4.45)
C	mm (in)	5 (0.2)	134 (5.3)	132 (5.2)	134 (5.3)	160 (6.3)	197 (7.8)	160 (6.3)	157 (6.1)	160 (6.3)	185 (7.3)	197 (7.8)
D	mm (in)	8 (0.3)	246 (9.7)	259 (10.2)	259 (10.2)	284 (11.2)	322 (12.7)	272 (10.7)	284 (11.2)	284 (11.2)	310 (12.2)	322 (12.7)
E	mm (in)	18 (0.7)	916 (36.1)	932 (36.7)	932 (36.7)	957 (37.7)	995 (39.2)	941 (37.1)	958 (37.7)	958 (37.7)	983 (38.7)	995 (39.2)
EM	mm (in)	19 (0.75)	917 (36.1)	933 (36.7)	933 (36.7)	958 (37.7)	996 (39.2)	942 (37.1)	959 (37.8)	959 (37.8)	984 (38.7)	996 (39.2)
F	mm (in)	10 (0.4)	368 (14.5)	381 (15.0)	381 (15.0)	406 (16.0)	445 (17.5)	394 (15.5)	406 (16.0)	406 (16.0)	432 (17.0)	445 (17.5)
H	mm (in)	18 (0.7)	351 (13.8)	364 (14.3)	364 (14.3)	390 (15.3)	428 (16.9)	X X	X X	X X	X X	X X
HB	mm (in)	0.3 (0.1)	73 (2.9)	85 (3.4)	85 (3.4)	98 (3.9)	111 (4.4)	X X	X X	X X	X X	X X
HC	mm (in)	5 (0.2)	134 (5.3)	132 (5.2)	135 (5.3)	160 (6.3)	199 (7.8)	X X	X X	X X	X X	X X
HD	mm (in)	10 (0.4)	162 (6.4)	175 (6.9)	175 (6.9)	200 (7.9)	238 (9.4)	X X	X X	X X	X X	X X
J	mm (in)	10 (0.4)	380 (15)	393 (15.5)	393 (15.5)	418 (16.5)	456 (18)	405 (16)	418 (16.5)	418 (16.5)	444 (17.5)	456 (18)
L	mm (in)	10 (0.4)	338 (13.3)	351 (13.8)	351 (13.8)	376 (14.8)	414 (16.3)	363 (14.3)	376 (14.8)	376 (14.8)	401 (15.8)	414 (16.3)
M	mm (in)	8 (0.3)	516 (20.3)	X X	X X	X X	X X	516 (20.3)	X X	X X	X X	X X
N	mm (in)	10 (0.4)	278 (11)	292 (11.5)	292 (11.5)	318 (12.5)	355 (14)	305 (12)	318 (12.5)	318 (12.5)	243 (13.5)	355 (14)

GEM Series Coaxial HPGe Detector Product Configuration Guide

**Note: Cryostat/Dewar drawings are NOT to scale, see tables that follow for complete dimensions.
Dimensions are for reference only and subject to change, if dimensional constraints are critical, contact the factory.**

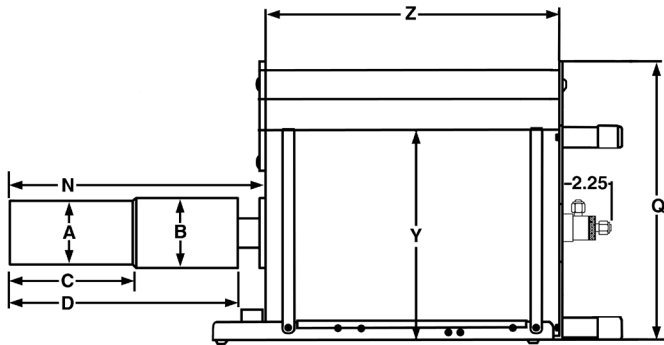

**CFG-PG4-1.2 (or -3 or -5) or
CFG-GG, DWR-1.2G (or -3.0G, -5.0G)**

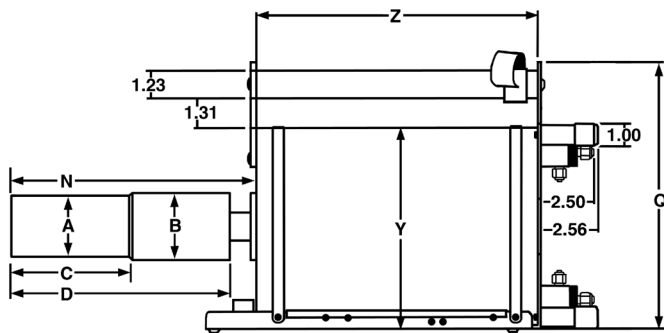

**CFG-PMOD4-3 (or -7) or
CFG-GG, DWR-MOD3L (or -MOD7L)**

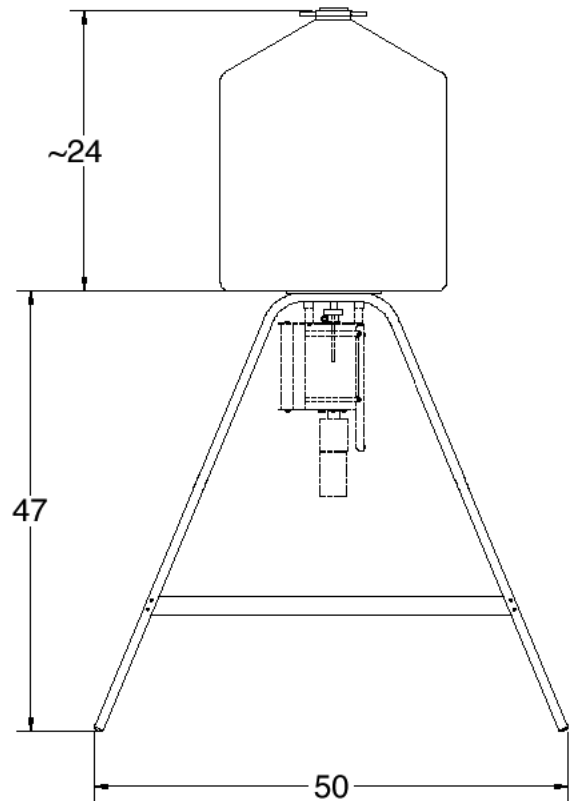

DWR-S/F

Gamma Gage and Side-Looking Dewar Dimensions

- Dimensions are for reference only and subject to change.
- If dimensional constraints are critical, contact the factory.

			Cryostat/Dewar or Dewar Type							
			CFG-PG4 and DWR-x.xG			CFG-PMOD4 and DWR-MOD-xL		CFG-PS4, CFG-PD4, DWR-xxB and DWR-xxD		
			VOLUME		VOLUME		VOLUME			
Dim.	Unit	Tol. ±	1.2L	3L	5L	3L	7L	7.5L	13L	30L
Q	mm (in)	13 (0.5)	229 (9.0)	302 (11.9)	302 (11.9)	229 (9.0)	302 (11.9)	X X	X X	X X
R	mm (in)	10 (0.4)	X X	X X	X X	X X	X X	174 (6.9)	174 (6.9)	155 (6.1)
S	mm (in)	7.6 (0.3)	X X	X X	X X	X X	X X	77 (3.0)	77 (3.0)	60 (2.3)
T	mm (in)	5 (0.2)	X X	X X	X X	X X	X X	10 (0.4)	10 (0.4)	13 (0.5)
Y	mm (in)	13 (0.5)	157 (6.2)	229 (9.0)	229 (9.0)	157 (6.2)	229 (9.0)	224 (8.8)	307 (12.1)	442 (17.4)
Z	mm (in)	5 (0.2)	229 (9.0)	267 (10.5)	419 (16.5)	292 (11.5)	320 (12.6)	452 (17.8)	429 (16.9)	610 (24.0)

GEM Series Coaxial HPGe Detector

Product Configuration Guide

Note: Cryostat/Dewar drawings are NOT to scale, see tables that follow for complete dimensions. Dimensions are for reference only and subject to change, if dimensional constraints are critical, contact the factory.

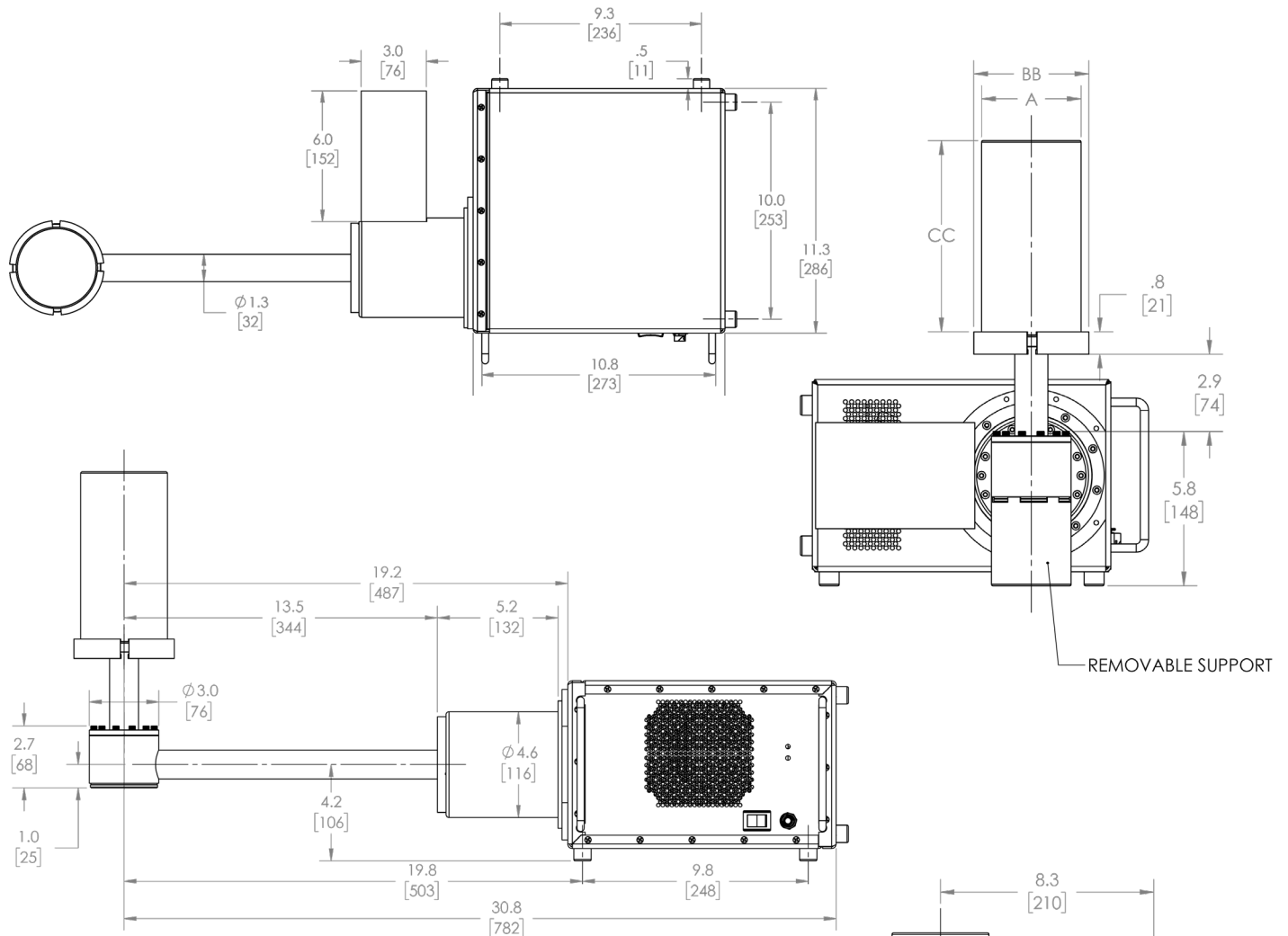

ICS-HJ GEM Detector Dimensions							
Endcap Model (dia. mm)			-70	-76	-83	-95	-108
% Efficiencies available in this endcap size			0-20	25-40	45-55	60-110	120-150
Dim.	Unit	Tol.					
A	mm (in)	0.3 (0.01)	70 (2.75)	76 (3.0)	83 (3.25)	95 (3.75)	108 (4.25)
BB	mm (in)	0.3 (0.01)	85 (3.4)	92 (3.6)	98 (3.9)	111 (4.4)	124 (4.9)
CC	mm (in)	5 (0.2)	145 (5.7)	158 (6.2)	158 (6.2)	183 (7.2)	183 (7.2)

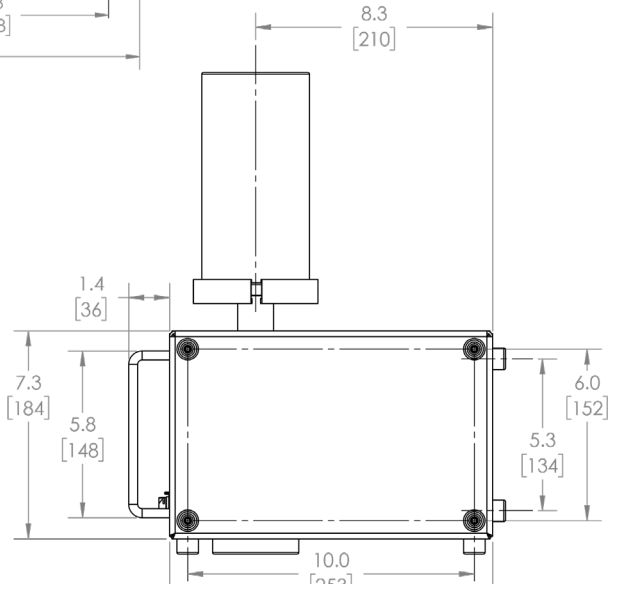

GEM Series Coaxial HPGe Detector Product Configuration Guide

**Note: Cryostat/Dewar drawings are NOT to scale, see tables that follow for complete dimensions.
Dimensions are for reference only and subject to change, if dimensional constraints are critical, contact the factory.**

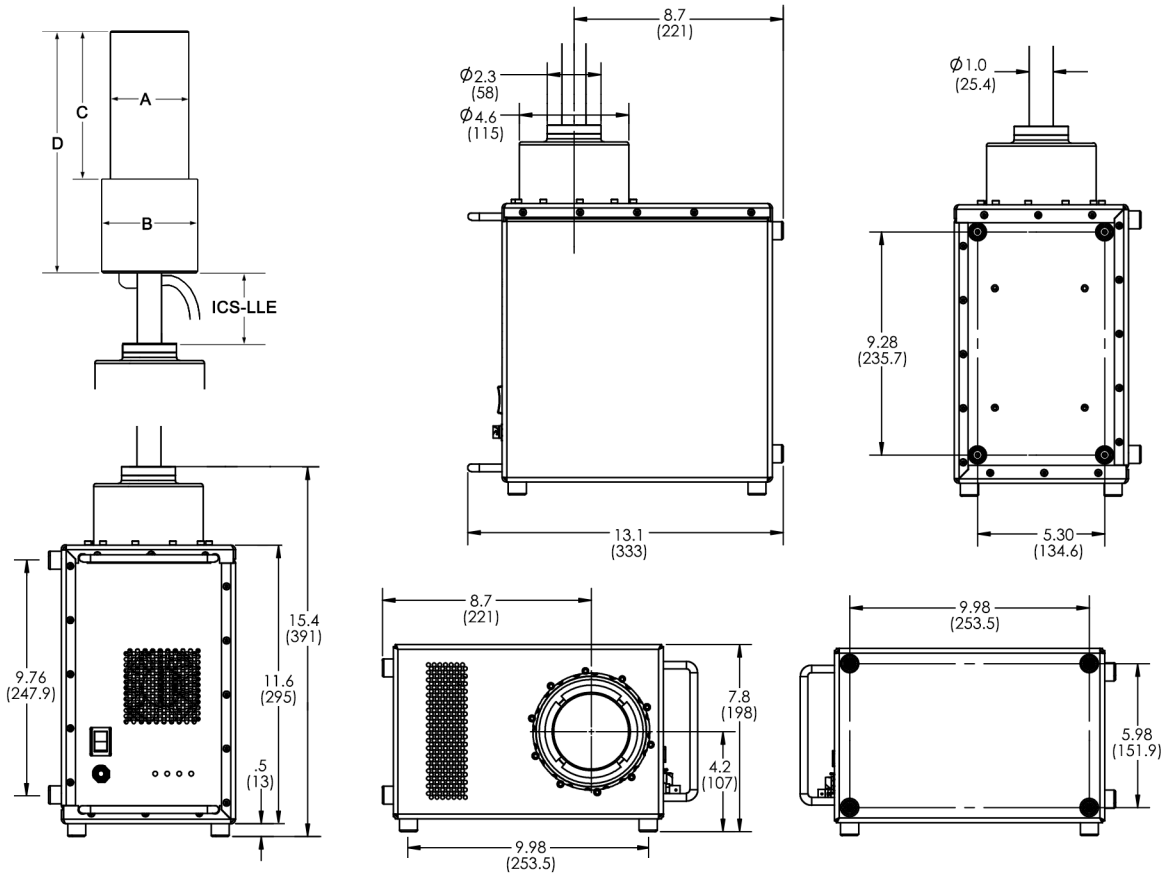

CFG-ICS-E

Streamline GEM Detector Dimensions for ICS-E Integrated Cryocooling System

- Dimensions are for reference only and subject to change.
- If dimensional constraints are critical, contact the factory.

Endcap Model (dia. mm)			-70	-76	-83	-95	-108
% Efficiencies available in this endcap size			0-20	25-40	45-55	60-110	120-150
Dim.	Unit	Tol.					
A	mm (in)	0.3 (0.01)	70 (2.75)	76 (3.0)	83 (3.25)	95 (3.75)	108 (4.25)
B	mm (in)	0.3 (0.01)	101 (4.0)	101 (4.0)	101 (4.0)	114 (4.4)	127 (5.0)
C	mm (in)	5 (0.2)	144 (5.7)	157 (6.2)	157 (6.2)	182 (7.2)	182 (7.2)
D	mm (in)	5 (0.2)	243 (9.6)	256 (10.1)	256 (10.1)	281 (11.1)	281 (11.1)
ICS-LLE	mm	3	Specify length. Choose from 025, 114, 139, 190.*				

*Recommended cooling rod length (ICS-LLE): 139 mm for use with 4" lead shield; 190 mm for use with 6" lead shield. Other lengths available by special order.

GEM Series Coaxial HPGe Detector Product Configuration Guide

GEM Endcap Diameter and Window

The endcap size must be specified by adding the endcap Model (-xx) to the Detector Model (e.g., GEM25-76 or GEM60P4-95).

If this, or any other dimension is critical, please specify at time of order.

Endcap Model (dia. mm)	-70	-76	-83	-95	-108
Endcap Diameter (in)	2.75	3.00	3.25	3.75	4.25
Efficiency	0–20%	25–40%	45–55%	60–110%	120–150%
Thickness of Al Window	1 mm	1 mm	1 mm	1.5 mm	1.5 mm
Thickness of CF Window	.9 mm nominal	.9 mm nominal	.9 mm nominal	.9 mm nominal	.9 mm nominal

GEM Series Coaxial HPGe Detector Product Configuration Guide

Defining the Detector Model

• See ordering information for option compatibility.

Base Model (example)	PopTop or Streamline	Endcap Diameter	ICS Option (if required)	Window Option (if required)	Preamplifier Option (if required)	High Voltage Option (if required)
GEM10	P4 (PopTop) (Streamline)	-70 -76 -83 -95 -108	-ICS-E -ICS-HJ -ICS-LB-HJ	-RB -LB-C -XLB-C	-PL -HJ	-SMP

Example Model Numbers

PopTop Configuration

GEM10P4-70 CFG-PH4 MOBIUS-PT	10% efficiency GEM detector with 70-mm diameter endcap. Horizontal Dipstick type cryostat. Möbius Recycler.
GEM35P4-76-SMP CFG-PD4-7.5	35% efficiency GEM detector with 76-mm diameter endcap and SMART-1 preamplifier and high voltage supply. Downlooking cryostat with 7.5 liter dewar.
GEM50P4-83-RB-SMP CFG-PV4 DWR-30	50% efficiency GEM detector with 83-mm diameter reduced background carbon fiber endcap and SMART-1 preamplifier and high voltage supply. Vertical “dipstick” style cryostat. 30 liter top port dewar that accepts “dipstick” style cryostats.
GEM75P4-95 CFG-ICS-P4	75% efficiency GEM detector with 95-mm diameter endcap. Integrated Cryocooling System

Streamline Configuration

GEM10-70 CFG-GG-70 DWR-1.2G	10% efficiency GEM detector with 70-mm diameter endcap. Portable Gamma Gage cryostat with matching 70-mm diameter flange. 1.2 liter all-position dewar for Gamma Gage cryostat.
GEM35-76-SMP CFG-SD-76 DWR-7.5D	35% efficiency GEM detector with 76-mm diameter endcap and SMART-1 preamplifier and high voltage supply. Down-looking cryostat with matching 76-mm diameter flange. 7.5 liter down-looking dewar.
GEM50-83-HJ CFG-HJ-83 DWR-30B	50% efficiency GEM detector with 83-mm diameter endcap and remote preamplifier and high voltage filter. “J” configuration cryostat with matching 83-mm diameter flange, and remote fittings for the preamplifier and high voltage filter. 30 liter side-looking dewar for “HJ” cryostat.

Streamline with Integrated Cryocooling System (ICS) Configuration

GEM35-76-ICS-E-SMP CFG-ICS-E ICS-LLE114-76	35% efficiency GEM detector with 76-mm diameter endcap in an ICS integrated cryocooling system with external preamp, SMART-1 preamplifier and high voltage supply. Integrated Cryocooling System with external preamp. 114-mm cooling rod length with matching 76-mm diameter flange.
GEM55-83-ICS-HJ	55% efficiency GEM detector with 83-mm diameter endcap in an ICS-HJ integrated cryocooling system with remote preamp and high voltage filter.
GEM100-95-ICS-LB-HJ	100% efficiency GEM detector with 95-mm diameter endcap in an ICS-LB-HJ integrated cryocooling low-background system with remote preamp and high voltage filter, low-background high purity aluminum endcap and OFHC Cu mount.

GEM Series Coaxial HPGe Detector

Product Configuration Guide

Ordering Information and Warranted Specifications

- Endcap Diameter must be specified. See Defining the Detector Model on page 17.
- Cryostat and dewar or other cooling device are not included with detector and are required for operation.
- A cryostat must be ordered with a Streamline detector.
- Monte Carlo drawing and certified factory test results are included.

Base Model No.	Relative Photopeak Efficiency (%) (Minimum)	Resolution		Peak-to-Compton Ratio (Minimum)	Peak Shape*		Endcap Diameter (mm) Nominal
		@122 keV (keV) FWHM (Maximum)	@1.33 MeV (keV) FWHM (Maximum)		FW.1M/ FWHM (Maximum)	FW.02M/ FWHM (Typical)	
GEM10	10	0.80	1.8	41:1	1.9	2.6	-70
GEM15	15	0.82	1.8	46:1	1.9	2.6	-70
GEM20	20	0.82	1.8	52:1	1.9	2.6	-70
GEM25	25	0.82	1.9	56:1	1.9	2.6	-76
GEM30	30	0.85	1.9	60:1	1.9	2.6	-76
GEM35	35	0.85	1.9	62:1	1.9	2.6	-76
GEM40	40	0.87	1.9	64:1	1.9	2.6	-76
GEM45	45	0.90	1.9	64:1	1.9	2.6	-83
GEM50	50	0.90	1.9	66:1	1.9	2.6	-83
GEM55	55	1.00	1.9	67:1	1.9	2.8	-83
GEM60	60	1.00	2.0	70:1	1.9	3.0	-95
GEM65	65	1.00	2.0	73:1	1.9	3.0	-95
GEM70	70	1.00	2.0	75:1	2.0	3.0	-95
GEM75	75	1.10	2.0	77:1	2.0	3.0	-95
GEM80	80	1.10	2.0	77:1	2.0	3.0	-95
GEM90	90	1.20	2.0	80:1	2.0	3.0	-95
GEM100	100	1.20	2.1	83:1	2.0	3.0	-95
GEM110	110	1.30	2.1	85:1	2.0	3.0	-95
GEM120	120	1.30	2.1	86:1	2.0	3.1	-108
GEM130	130	1.30	2.1	90:1	2.0	3.1	-108
GEM140	140	1.30	2.2	90:1	2.0	3.1	-108
GEM150	150	1.30	2.3	90:1	2.0	3.1	-108

Notes:

- 1) FWHM = Full Width at Half Maximum; FW.1M = Full Width at One-Tenth Maximum; FW.02M = Full Width at One-Fiftieth Maximum; total system resolution measured at the factory in accordance with ANSI/IEEE Std. 325-1996.
- 2) Measured at optimal shaping time using an ORTEC DSPEC-50A.

GEM Series Coaxial HPGe Detector Product Configuration Guide

GEM Detector Options

- Append suffix to base model number.
- Endcap Diameter must be specified. See Defining the Detector Model on page 17.

Suffix	Description
P4	<u>PopTop Only</u> . PopTop capsule, add "P4" to the model number.
-RB	<u>PopTop Only</u> . Reduced background PopTop capsule with Carbon Fiber endcap, add "-RB" to the model number.
-LB-C	<u>Streamline Only</u> . Low-Background Detector with Carbon Fiber Endcap, add "-LB-C" to the model number. Requires selection of a Low-Background LB cryostat.
-XLB-C	<u>Streamline Only</u> . Extra-Low-Background Detector with Carbon Fiber Endcap, add "-XLB-C" to the model number. Requires selection of a Low-Background XLB cryostat.
-HJ	<u>Streamline Only</u> . Remote preamplifier and high voltage filter for use with HJ type cryostat, add "-HJ" to the model number. Requires selection of HJ cryostat. Not compatible with -PL or -SMP options.
-ICS-E	<u>ICS Streamline Only</u> . Integrated Cryocooling System with external preamp. Cryostat sealed with a cryocooler and immune to thermal short cycling, add "-ICS-E" to the model number. Requires selection of an ICS-E cryostat.
-ICS-HJ	<u>ICS Streamline Only</u> . Integrated Cryocooling System with remote preamp and high voltage filter. Cryostat sealed with a cryocooler and immune to thermal short cycling, add "-ICS-HJ" to the model number. This option is inclusive of cryostat and does not require selection of an additional cryostat. Not compatible with other options.
-ICS-LB-HJ	<u>ICS Streamline Only</u> . Integrated Cryocooling System with remote preamp and high voltage filter, High Purity Al Endcap and Cu Mount. Cryostat sealed with a cryocooler and immune to thermal short cycling, add "-ICS-HJ" to the model number. This option is inclusive of cryostat and does not require selection of an additional cryostat. Not compatible with other options.
-PL	PLUS Ultra-high-count-rate Preamplifier, add "-PL" to the model number. Not compatible with -HJ option.
-SMP	SMART-1 detector option for positive bias detector, add "-SMP" to the model number. Not compatible with -HJ option.

GEM Series Coaxial HPGe Detector

Product Configuration Guide

GEM PopTop Cryostats and Dewars

Model No.	Description
CFG-MG4-1.2G	Gamma Gage Cryostat with 1.2-liter Dewar, Pistol Grip handle and mounting holes to fit the M-1-T1 Tripod (for 83 mm or smaller endcaps)
CFG-PD4-7.5	Down-looking Cryostat with 7.5-liter Dewar
CFG-PD4-13	Down-looking Cryostat with 13-liter Dewar
CFG-PD4-30	Down-looking Cryostat with 30-liter Dewar
CFG-PG4-1.2	Gamma Gage Cryostat with 1.2-liter Dewar (for 83 mm or smaller endcaps)
CFG-PG4-3	Gamma Gage Cryostat with 3-liter Dewar
CFG-PG4-5	Gamma Gage Cryostat with 5-liter Dewar
CFG-PH4	Horizontal Cryostat (Dipstick type). Choose DWR-30, DWR-30-OP, MOBIUS-PT or MOBIUS-PT-DET.
CFG-PMOD4-3	Gamma Gage Cryostat with 3-liter Multi-Orientation Dewar
CFG-PMOD4-7	Gamma Gage Cryostat with 7-liter Multi-Orientation Dewar
CFG-PS4-7.5	Side-Looking Cryostat with 7.5-liter Dewar
CFG-PS4-13	Side-Looking Cryostat with 13-liter Dewar
CFG-PS4-30	Side-Looking Cryostat with 30-liter Dewar
CFG-PS4-MOBIUS-B	Side-Looking Cryostat with Möbius Recycler 28-liter Dewar
CFG-PS4-MOBIUS-B-DET	Side-Looking Cryostat with Möbius Recycler 28-liter Dewar for purchase in combination with any PopTop detector.
CFG-PSHP4	Down-Looking Shallow-Hole Probe with 0.7-liter Dewar
CFG-PV4	Vertical Cryostat (Dipstick type). Choose DWR-30, DWR-30-OP, MOBIUS-PT or MOBIUS-PT-DET.
CFG-ICS-P4	Integrated Cryocooling System
MOBIUS-PT	Möbius Recycler.
MOBIUS-PT-DET	Möbius Recycler Dewar for purchase in combination with any PopTop detector and vertical or horizontal dipstick cryostat.
DWR-30	30-liter Dewar. Includes collar for 1.5" diameter cryostat.
DWR-30-OP	30-liter Offset-Port Dewar. Includes collar for 1.5" diameter cryostat.
DWR-S/F	Storage Fill Dewar for CFG-PG4-X

GEM Series Coaxial HPGe Detector Product Configuration Guide

GEM Streamline Cryostats

- May only be purchased with a detector.
- Append matching Detector Endcap Size designation to cryostat model: -70, -76, -83, -95, -108 [e.g., CFG-SJ-95 for GEM75-95, or CFG-SL-XLB-76 for GEM25-76-XLB-C]
- Dewar required. Select dewar from GEM Streamline Dewars.
- Horizontal and Vertical Cryostats include CFG-ADAPTOR to increase cryostat diameter from 1.25 inch to 1.5 inch for use with DWR-30 and DWR-30-OP.

Model No.	Description
CFG-GG	Gamma Gage Cryostat
CFG-HJ	J-type Cryostat with Remote Preamp. (for -HJ option only)
CFG-SD	Down-Looking Cryostat
CFG-SH	Horizontal Cryostat (Dipstick type).
CFG-SJ	J-type Cryostat
CFG-SL	Side-Looking Cryostat
CFG-SV	Vertical Cryostat (Dipstick type).

LOW-BACKGROUND

CFG-GG-LB	Low-Background Gamma Gage Cryostat
CFG-HJ-LB	Low-Background J-type Cryostat with Remote Preamp. (for -HJ option only)
CFG-SD-LB	Low-Background Down-Looking Cryostat
CFG-SH-LB	Low-Background Horizontal Cryostat (Dipstick type).
CFG-SJ-LB	Low-Background J-type Cryostat
CFG-SL-LB	Low-Background Side-Looking Cryostat
CFG-SV-LB	Low-Background Vertical Cryostat (Dipstick type).
CFG-SD-XLB	Extra-Low-Background Down-Looking Cryostat
CFG-SH-XLB	Extra-Low-Background Horizontal Cryostat (Dipstick type).
CFG-SJ-XLB	Extra-Low-Background J-type Cryostat
CFG-SL-XLB	Extra-Low-Background Side-Looking Cryostat
CFG-SV-XLB	Extra-Low-Background Vertical Cryostat (Dipstick type).

GEM ICS-E Cryostat

- May only be purchased with a detector.
- Append matching Detector Endcap Size designation to Cooling Rod Length model: -70, -76, -83, -95, -108 [e.g., CFG-ICS-E, ICS-LL139-76 for GEM25-76-ICS-E].

Model	Description
CFG-ICS-E	Integrated Cryocooling System with External Preamp. Cooling Rod Length must be specified, see below. Cooling Rod Length. Add as separate line item ICS-LLExxx where xxx = one of the following lengths (mm): 025, 114, 139, 190*, and append matching Detector Endcap Size [e.g., ICS-LLE190-70].

*Recommended cooling rod length (ICS-LLE): 139 mm for use with 4" lead shield. 190 mm for use with 6" lead shield. Other lengths available by special order.

GEM Series Coaxial HPGe Detector

Product Configuration Guide

GEM Streamline Dewars

For Cryostat	Choose	Description
CFG-GG	DWR-1.2G	1.2-liter All-Orientation Dewar
	DWR-3.0G	3.0-liter All-Orientation Dewar
	DWR-5.0G	5.0-liter All-Orientation Dewar
	DWR-MOD-3L	3-liter Multi-Orientation Dewar
	DWR-MOD-7L	7-liter Multi-Orientation Dewar
	DWR-0.7-SHP-G	0.7-liter Shallow-Hole Probe Dewar
	DWR-S/F	Storage/Fill Dewar for DWR-XG
CFG-HJ, SJ, SL	DWR-7.5B	7.5-liter Side-Looking Dewar
	DWR-13B	13-liter Side-Looking Dewar
	DWR-30B	30-liter Side-Looking Dewar
	MOBIUS-B	Möbius Recycler Side-Looking Dewar
CFG-SD	DWR-7.5D	7.5-liter Down-Looking Dewar
	DWR-13D	13-liter Down-Looking Dewar
	DWR-30D	30-liter Down-Looking Dewar
CFG-SV, SH	DWR-30	30-liter Dewar. Includes collar for 1.5" diameter cryostat.
	DWR-30-OP	30-liter Offset-Port Dewar. Includes collar for 1.5" diameter cryostat.
	MOBIUS-ST	Möbius Recycler Dewar for purchase stand alone
	MOBIUS-ST-DET	Möbius Recycler Dewar for purchase in combination with Detector

GEM Series Coaxial HPGe Detector Product Configuration Guide

GEM Series Coaxial HPGe Detector Product Configuration Guide



www.ortec-online.com

Tel. (865) 482-4411 ortec.info@ametek.com

801 South Illinois Avenue, Oak Ridge, TN 37830 U.S.A.

Visit Our Website For International Office Locations

Specifications subject to change
25-0204