

### For Analysis of Small, Low-Activity Samples

- High absolute counting efficiency for small samples
- Active Volumes to 400 cc
- Unique ion-implanted blind well
- Resolution specified with source inside the well
- Spectroscopy from 10 keV to 10 MeV
- Near  $4\pi$  geometry
- Extra-large well (1.55 x 4.0 cm) standard

ORTEC High-Purity Germanium (HPGe) Well Detectors offer high absolute counting efficiency for radiochemical analysis and low-level gamma-ray spectroscopy. The unique ion-implanted detector well has an ultra-thin dead layer (only 0.3  $\mu\text{m}$  thick), and therefore provides the most extensive useful energy range (10 keV to 10 MeV). Unlike other Well detectors that have a hole all the way through the germanium crystal, ORTEC Well Detectors have a "blind hole" with at least 5 mm of active germanium at the bottom of the hole (Fig. 1). This near  $4\pi$  geometry provides the maximum absolute counting efficiency available. The large well (1.55-cm-diameter and 4.0-cm-long) accommodates an extensive range of sample sizes. Like all ORTEC HPGe photon detectors, the HPGe Well detector may be stored or cycled repeatedly to room temperature without performance degradation.

As specified in ANSI/IEEE Std. 325-1996, the resolution is measured with a point source inside the well, 1 cm from the bottom. Measurements of resolution outside the well can be deceiving.

A typical curve of absolute efficiency in the well vs. photon energy is shown in Fig. 2.

### The Following Specifications are Provided for Each Model GWL Detector

- Energy resolution at 1.33-MeV photons from  $^{60}\text{Co}$  at optimum shaping time.
- Active Ge volume and well tube diameter.
- Energy resolution at 122 keV photons from  $^{57}\text{Co}$  at optimum shaping time.

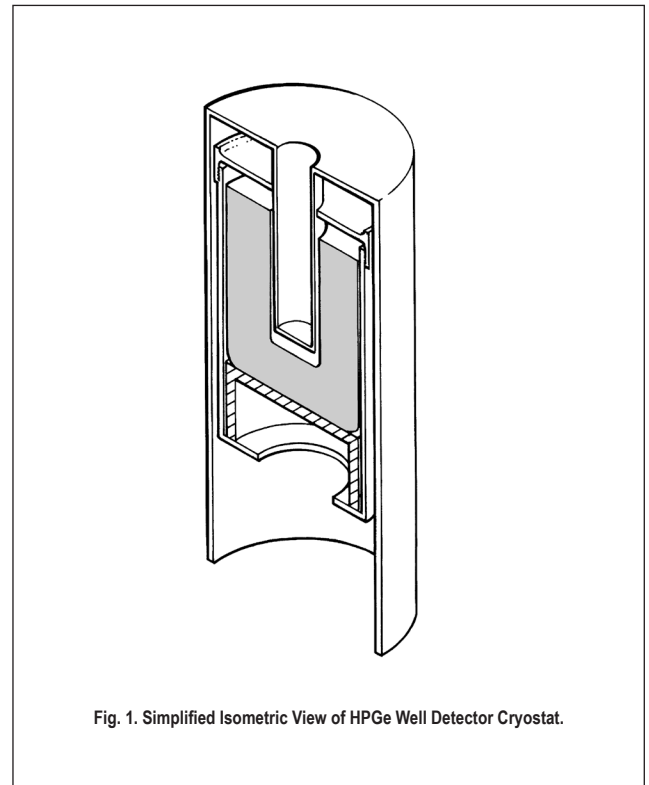

Fig. 1. Simplified Isometric View of HPGe Well Detector Cryostat.

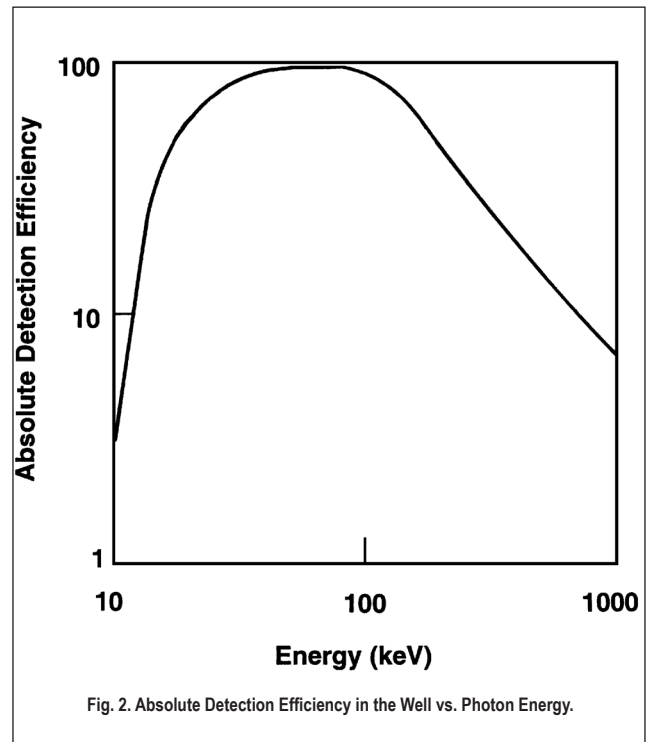

Fig. 2. Absolute Detection Efficiency in the Well vs. Photon Energy.

# GWL Series Coaxial HPGe Detector

## Product Configuration Guide

### Configuration Guidelines

#### Streamline (non-PopTop) Configuration

In so called Streamline systems, the detector capsule is NOT demountable. Detector capsule and cryostat share the same vacuum. In configuration terms, this requires a cryostat or cryostat/dewar selection with the cryostat having a matching diameter to the capsule endcap. A cryostat must always be ordered with a Streamline capsule, because they are integral.

#### Steps to Configure Your ORTEC HPGe Detector

##### 1) Configure the Detector Model

- Ge Crystal active volume and well tube diameter
- Endcap and window
- Mount
- Preamplifier
- High Voltage Filter
- Cable Package

Options are available for the detector model that can change specific materials used in the construction of the detector endcap, cup, and mount. Preamplifier options are also available.

##### 2) Configure the Cryostat/Dewar Model

- Vertical Dipstick style (separate Dewar or Mobius Recycler)
- Sidelooking designed to be oriented with the detector horizontal at the bottom of the dewar
- “J” configurations designed with the detector attached near the bottom of the dewar and a right angle bend in the cryostat orienting the detector to look up.

A cryostat and dewar or other cooling device are required for operation.

You must choose a cryostat or cryostat/dewar model for the detector to be mounted on and vacuum sealed. The cryostat or cryostat/dewar combination diameter must match the endcap diameter of the selected detector.

### Detector Options

#### Remote Preamplifier Option (-HJ)

This option allows all the preamplifier and high voltage connections to be outside a shield and removes the preamplifier and high voltage filter from the “line-of-sight” to the Ge crystal. For low background applications, this option eliminates any possible preamplifier or high voltage filter components that may add to the background inside a shield.

#### Low-Background Options (-LB-AWT, and -XLB-AWT)

Low-background GWL detectors are supplied with oxygen-free high conductivity (OFHC) copper endcaps with low-background high purity aluminum well tubes of 0.02 inch wall thickness.

### Defining the Detector Model

- See ordering information for option compatibility.

Base Model (example)	Well Option (if required)	Preamplifier Option (if required)
GWL-90-15	-LB-AWT -XLB-AWT	-HJ

# GWL Series Coaxial HPGe Detector Product Configuration Guide

## Streamline Detector Capsule

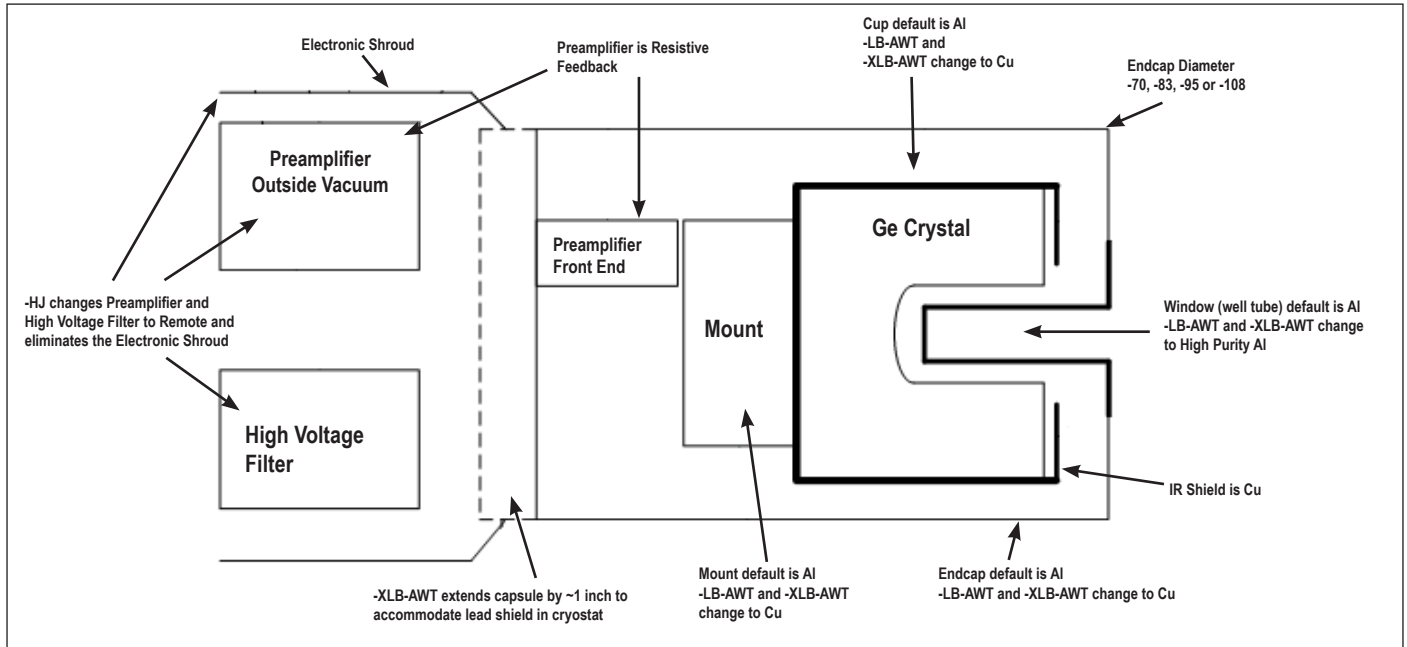

## Streamline Cryostat and Cryostat/Dewar Assemblies

Streamline systems (detector capsule and cryostat) share the same vacuum, requiring a cryostat or cryostat/dewar selection with the cryostat having a matching diameter to the capsule endcap.

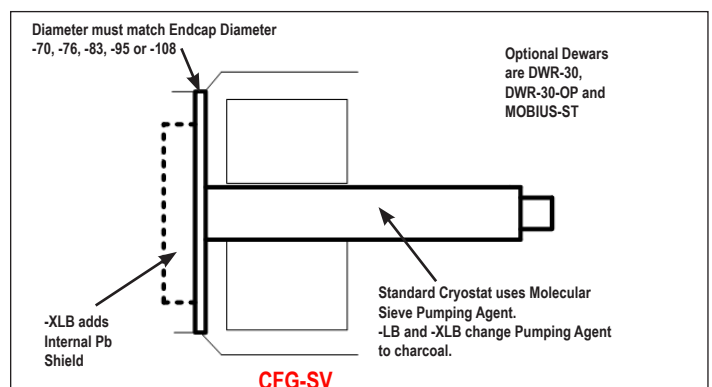
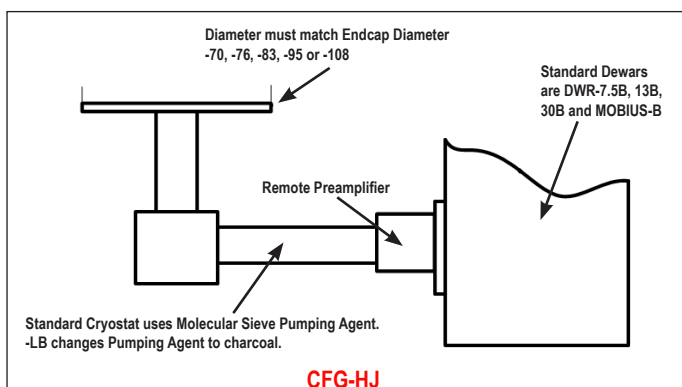
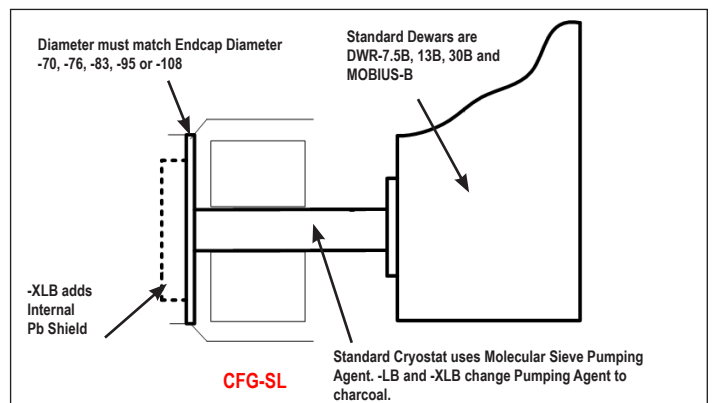
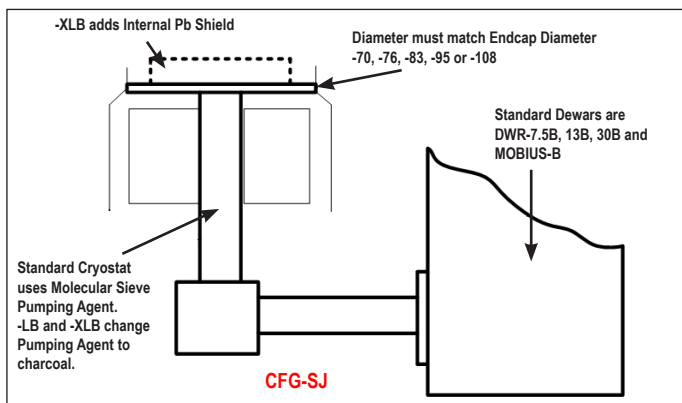

# GWL Series Coaxial HPGe Detector Product Configuration Guide

## PopTop and Streamline Dimensional Data

Streamline systems (detector capsule and cryostat or ICS) share the same vacuum. A cryostat or ICS must be ordered with a Streamline capsule. The cryostat or cryostat/dewar selection must have a matching diameter to the capsule endcap.

The PopTop capsule features an internal vacuum arrangement. It can be mounted on any of the available PopTop cryostats, cryostat/dewar combinations, or ICS-P4 mechanical cooling systems.

The cryostat and dewar drawings that follow are to be used in conjunction with the accompanying tables of dimensions.

**Note: Cryostat/Dewar drawings are NOT to scale, see tables that follow for complete dimensions. Dimensions are for reference only and subject to change, if dimensional constraints are critical, contact the factory.**

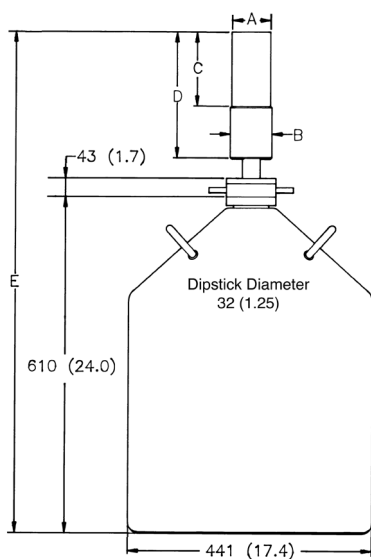

**CFG-SV, DWR-30**

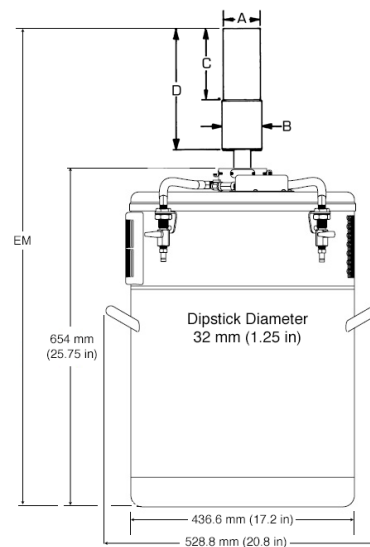

**CFG-SV, MOBIUS-ST**

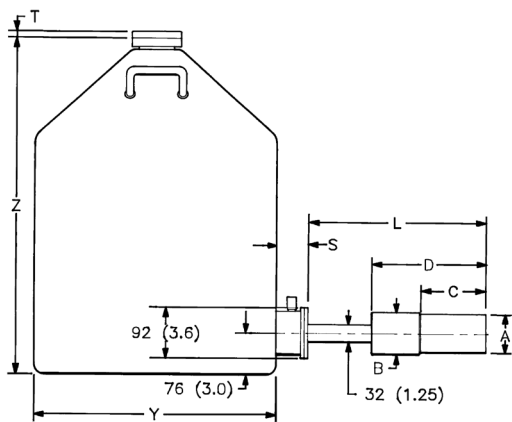

**CFG-SL, DWR-30B (or -13B or -7.5B)**

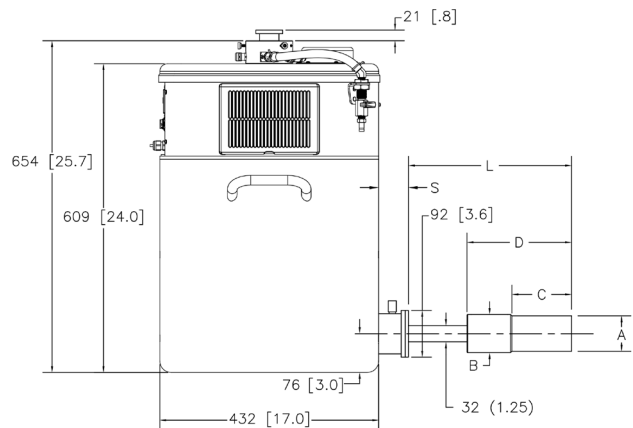

**CFG-SL, MOBIUS-B**

# GWL Series Coaxial HPGe Detector Product Configuration Guide

**Note: Cryostat/Dewar drawings are NOT to scale, see tables that follow for complete dimensions.  
Dimensions are for reference only and subject to change, if dimensional constraints are critical, contact the factory.**

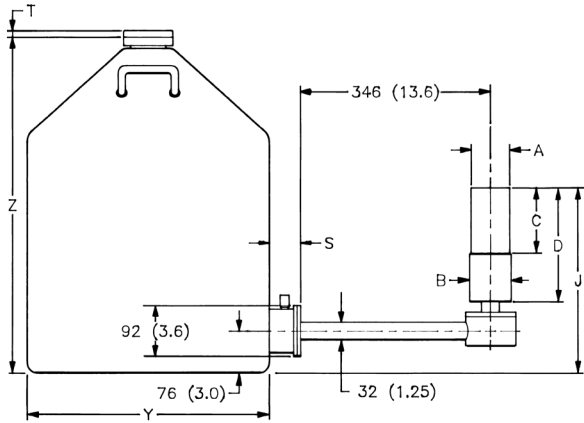

**CFG-SJ, DWR-30B (or -13B or -7.5B)**

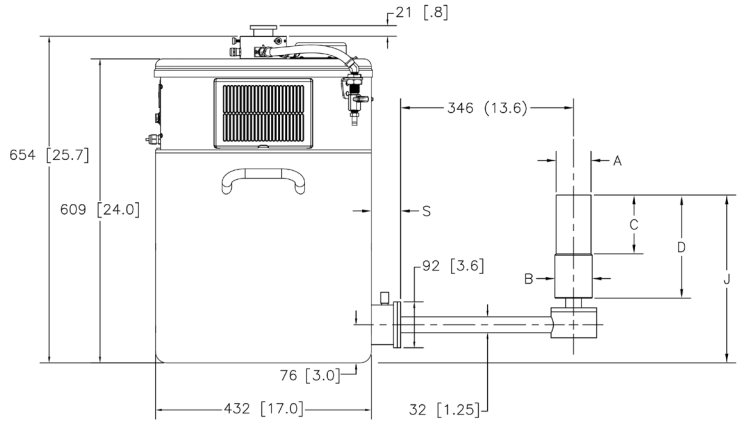

**CFG-SJ, MOBIUS-B**

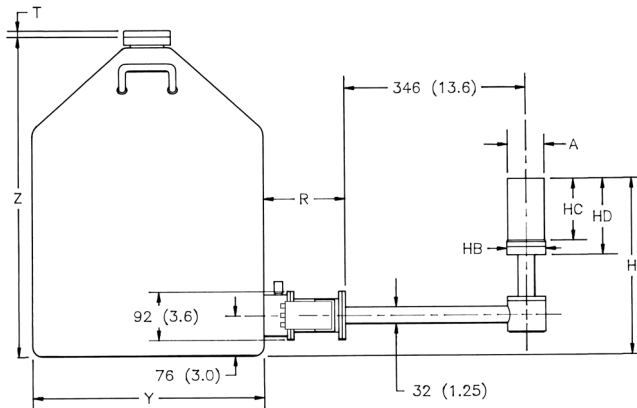

**CFG-HJ, DWR-30B (or -13B or -7.5B)**

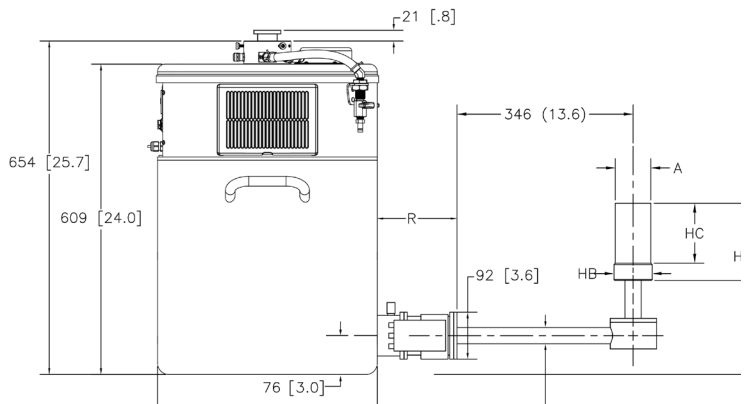

**CFG-HJ, MOBIUS-B**

# GWL Series Coaxial HPGe Detector

## Product Configuration Guide

### GWL Detector Dimensions

- Dimensions are for reference only and subject to change.
- If dimensional constraints are critical, contact the factory.

			Standard or LB				XLB			
Endcap Model (dia. mm)			-70	-83	-95	-108	-70	-83	-95	-108
Dim.	Unit	Tol.								
A	mm (in)	0.3 (0.01)	70 (2.75)	83 (3.25)	95 (3.75)	108 (4.25)	70 (2.75)	83 (3.25)	95 (3.75)	108 (4.25)
B	mm (in)	0.3 (0.01)	75 (2.95)	88 (3.45)	100 (3.95)	113 (4.45)	75 (2.95)	88 (3.45)	100 (3.95)	113 (4.45)
C	mm (in)	5 (0.2)	134 (5.3)	122 (4.8)	134 (5.3)	134 (5.3)	160 (6.3)	147 (5.8)	160 (6.3)	197 (7.8)
D	mm (in)	8 (0.3)	246 (9.7)	246 (9.7)	258 (10.2)	258 (10.2)	272 (10.7)	272 (10.7)	284 (11.2)	322 (12.7)
E	mm (in)	18 (0.7)	916 (36.1)	919 (36.2)	932 (36.7)	932 (36.7)	941 (37.1)	945 (37.2)	957 (37.7)	957 (37.7)
EM	mm (in)	19 (0.75)	917 (36.1)	920 (36.2)	933 (36.7)	933 (36.7)	942 (37.1)	946 (37.2)	958 (37.7)	995 (39.2)
H	mm (in)	18 (0.7)	352 (13.8)	352 (13.8)	364 (14.3)	364 (14.3)	X X	X X	X X	X X
HB	mm (in)	0.3 (0.1)	73 (2.9)	85 (3.4)	99 (3.9)	111 (4.4)	X X	X X	X X	X X
HC	mm (in)	5 (0.2)	134 (5.3)	122 (4.8)	135 (5.3)	135 (5.3)	X X	X X	X X	X X
HD	mm (in)	10 (0.4)	162 (6.4)	162 (6.4)	175 (6.9)	175 (6.9)	X X	X X	X X	X X
J	mm (in)	10 (0.4)	380 (15)	380 (15)	393 (15.5)	393 (15.5)	405 (16)	405 (16)	418 (16.5)	455 (18.0)
L	mm (in)	10 (0.4)	338 (13.3)	338 (13.3)	350 (13.8)	350 (13.8)	363 (14.3)	363 (14.3)	376 (14.8)	413 (16.3)

### Example Model Numbers

GWL-120-10	120 cc active volume GWL detector with 10-mm diameter well tube and 70-mm diameter endcap.
CFG-SV-70	Vertical "dipstick" style cryostat to fit 70-mm diameter endcap.
DWR-30	30 liter top port dewar that accepts "dipstick" style cryostats.
GWL-300-15-LB-AWT	300 cc active volume GWL detector with 15-mm diameter high purity Al (low-background) well tube and 95-mm diameter Cu endcap.
CFG-SL-LB-95	Sidelooking cryostat and dewar to fit 95-mm diameter endcap with low background charcoal pumping agent.
DWR-13B	13 liter sidelooking dewar.
GWL-450-10-XLB-AWT	450 cc active volume GWL detector with 10-mm diameter high purity Al (low-background) well tube with 108-mm diameter Cu endcap.
CFG-SJ-XLB "	J" type cryostat with lead shield and low-background charcoal pumping agent.
DWR-30B	30 liter side looking dewar.
GWL-170-15	170 cc active volume GWL detector with 15-mm diameter well tube and 83-mm diameter endcap.
CFG-SV-83	Vertical "dipstick" style cryostat to fit 70-mm diameter endcap.
MOBIUS-ST	Möbius Recycler.

# GWL Series Coaxial HPGe Detector Product Configuration Guide

## Ordering Information and Warranted Specifications

- If dimensional considerations are critical, contact factory.
- Cryostat and dewar or other cooling device are not included with detector and are required for operation.
- A cryostat must be ordered with a Streamline detector.

Model No.	Volume cc Nominal	Well Tube		Resolution		Endcap Diameter mm Nominal
		Diameter mm Nominal	Depth mm Nominal	@ 1.33 MeV keV FWHM Maximum	@ 122 keV keV FWHM Maximum	
GWL-90-10	90	10	40	2.1	1.2	70
GWL-90-15	90	15.5	40	2.3	1.4	70
GWL-110-10	110	10	40	2.1	1.2	70
GWL-110-15	110	15.5	40	2.3	1.4	70
GWL-120-10	120	10	40	2.1	1.2	70
GWL-120-15	120	15.5	40	2.3	1.4	70
GWL-130-10	130	10	40	2.1	1.2	70
GWL-130-15	130	15.5	40	2.3	1.4	70
GWL-150-10	150	10	40	2.1	1.2	83
GWL-150-15	150	15.5	40	2.3	1.4	83
GWL-170-10	170	10	40	2.1	1.2	83
GWL-170-15	170	15.5	40	2.3	1.4	83
GWL-190-10	190	10	40	2.1	1.2	83
GWL-190-15	190	15.5	40	2.3	1.4	83
GWL-220-10	220	10	40	2.1	1.2	95
GWL-220-15	220	15.5	40	2.3	1.4	95
GWL-250-10	250	10	40	2.1	1.2	95
GWL-250-15	250	15.5	40	2.3	1.4	95
GWL-280-10	280	10	40	2.2	1.2	95
GWL-280-15	280	15.5	40	2.3	1.4	95
GWL-300-10	300	10	40	2.2	1.2	95
GWL-300-15	300	15.5	40	2.3	1.4	95
GWL-350-10	350	10	40	2.2	1.2	95
GWL-350-15	350	15.5	40	2.3	1.4	95
GWL-400-10	400	10	40	2.2	1.2	108
GWL-400-15	400	15.5	40	2.3	1.4	108
GWL-450-10	450	10	40	2.2	1.2	108
GWL-450-15	450	15.5	40	2.3	1.4	108

## GWL Detector Options

- Append suffix to base model number.

Suffix	Description
-LB-AWT	Low-Background Detector with OFHC Cu Endcap and High Purity Al Well Tube, add "-LB-AWT" to the model number. Requires selection of a Low-Background LB cryostat.
-XLB-AWT	Extra-Low-Background Detector with OFHC Cu Endcap and High Purity Al Well Tube, add "-XLB-AWT" to the model number. Requires selection of a Low-Background XLB cryostat.
-HJ	Remote preamplifier and high voltage filter for use with HJ type cryostat, add "-HJ" to the model number. Requires selection of HJ cryostat.

# GWL Series Coaxial HPGe Detector Product Configuration Guide

## GWL Streamline Cryostats

- May only be purchased with a detector.
- Dewar required. Select dewar from GWL Streamline Dewars.
- Append matching Detector Endcap Size designation to cryostat model: -70, -83, -95, -108 [e.g., CFG-SJ-95 for GWL-280-15 or CFG-SL-XLB-83 for GWL-170-10-XLB-AWT]
- Vertical Cryostats include CFG-ADAPTOR to increase cryostat diameter from 1.25 inch to 1.5 inch for use with DWR-30 and DWR-30-OP.

Model No.	Description
CFG-HJ	J-type Cryostat with Remote Preamp. (for -HJ option only)
CFG-SJ	J-type Cryostat
CFG-SL	Side-Looking Cryostat
CFG-SV	Vertical Cryostat (Dipstick type).

## LOW-BACKGROUND

CFG-HJ-LB	Low-Background J-type Cryostat with Remote Preamp. (for -HJ option only)
CFG-SJ-LB	Low-Background J-type Cryostat
CFG-SL-LB	Low-Background Side-Looking Cryostat
CFG-SV-LB	Low-Background Vertical Cryostat (Dipstick type).
CFG-SJ-XLB	Extra-Low-Background J-type Cryostat
CFG-SL-XLB	Extra-Low-Background Side-Looking Cryostat
CFG-SV-XLB	Extra-Low-Background Vertical Cryostat (Dipstick type).

## GWL Streamline Dewars

For Cryostat	Choose	Description
CFG-HJ, SJ, SL	DWR-7.5B	7.5-liter Side-Looking Dewar
	DWR-13B	13-liter Side-Looking Dewar
	DWR-30B	30-liter Side-Looking Dewar
	MOBIUS-B	Möbius Recycler Side-Looking Dewar
CFG-SV	DWR-30	30-liter Dewar. Includes collar for 1.5" diameter cryostat.
	DWR-30-OP	30-liter Offset-Port Dewar. Includes collar for 1.5" diameter cryostat.
	MOBIUS-ST	Möbius Recycler Dewar for purchase stand alone
	MOBIUS-ST-DET	Möbius Recycler Dewar for purchase in combination with Detector