

# ORTEC<sup>®</sup>

AMETEK<sup>®</sup>

## PLS-System

Positron Lifetime Picosecond Timing System

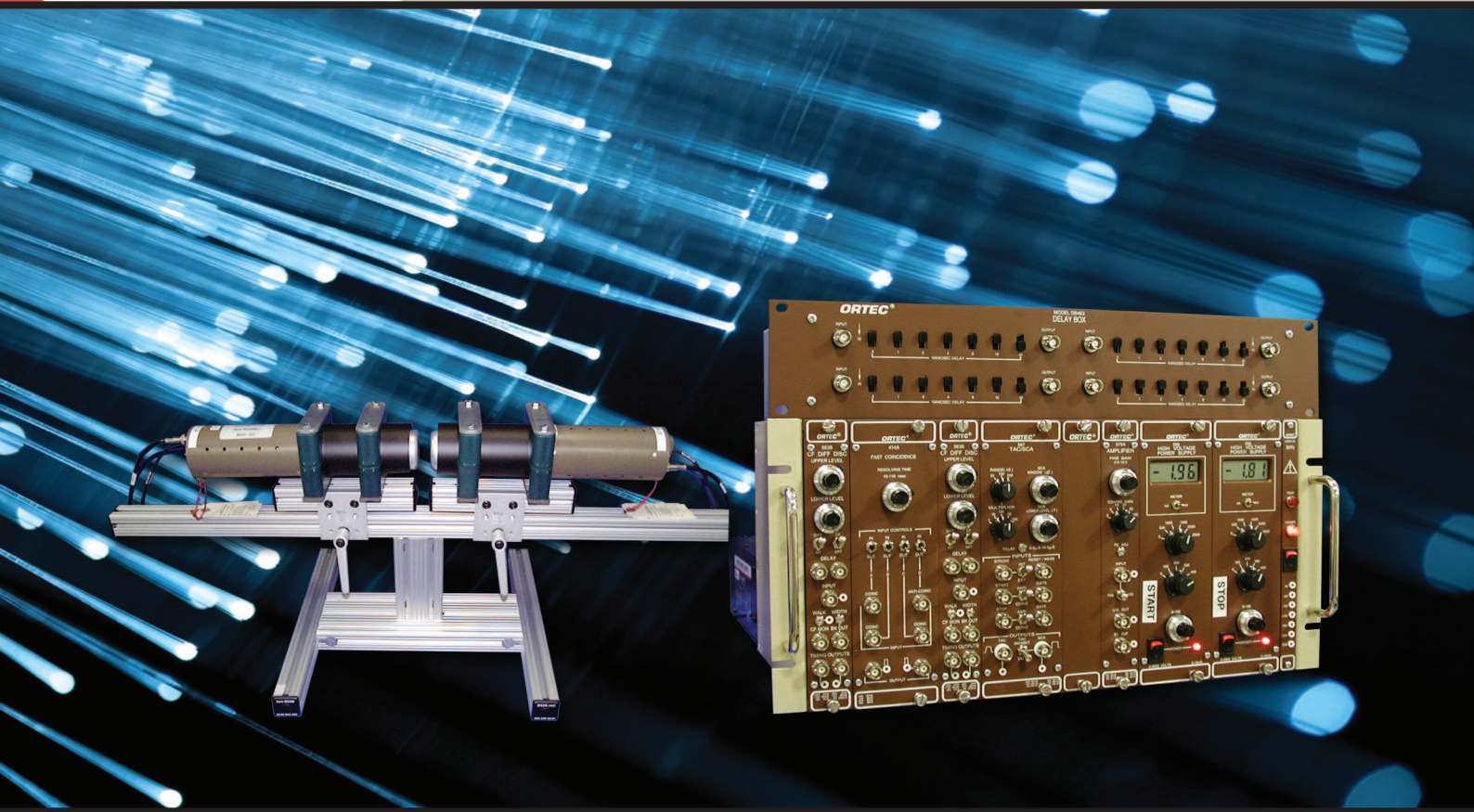

Positron Annihilation Lifetime Spectroscopy (PALS)

# PLS-System

## PLS-SYSTEM

### Positron Lifetime Picosecond Timing System

Positron Annihilation Lifetime Spectroscopy (PALS)

The existence of the positron, first predicted by Dirac, was experimentally identified in the 1930's. The positron is the antiparticle of the electron. A positron collision with an electron results in the annihilation of both particles and the emission of two characteristic 511-keV gamma rays.

This phenomenon is useful to test predictions of quantum theory with regard to the differences between electron and positron interactions with matter. In addition, the positron has proven to be a useful tool in the study of various structures and processes. The lifetime of the positron is a measure of the local electron density at the point of annihilation. The annihilation can be easily detected by virtue of the gamma rays emitted. Positron lifetime techniques are among the few methods sensitive to voids on the mono-atomic scale.

Since the early 1970's, ORTEC has been a major supplier of modular instrumentation for leading positron physicists and chemists world wide, as any positron conference proceeding can attest. The availability of positron sources makes the set-up of a positron lifetime system an attractive proposition for a teaching or research laboratory.

ORTEC makes the process even easier by providing a complete model PLS-SYSTEM.

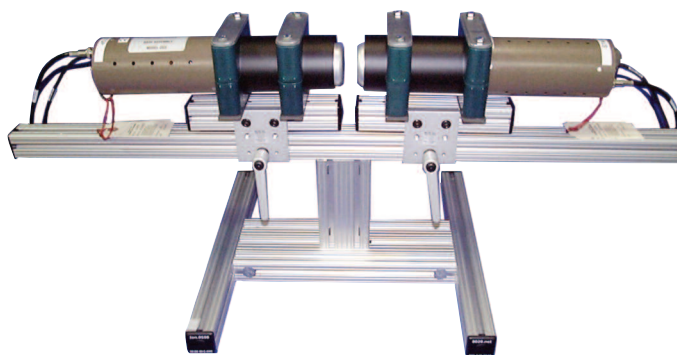

PALS Detectors mounted on the optional PLS-Slider.

### PALS: Opening It Up at the Nano-Level.

One of the most important structural aspects in soft condensed matter is the unoccupied or free volume which exists between the molecules due to irregular packing, density fluctuations and topological constraints. The free volume is considered as the volume fraction enabling molecular reorganization and is of fundamental importance in determining a system's physical and mechanical properties.

PALS is a well established, unique and versatile technique, which allows a direct measurement of these sub-nanometer sized molecular free volumes. PALS experiments proceed by injecting a positron into the material being tested and then measuring the length of time until it annihilates with one of the material's electrons producing gamma rays.

When a positron enters a molecular material it thermalizes, after which it may diffuse through the material either as a free particle or capture an electron to form the positronium atom (Ps). Ps is an electron-positron bound state, which has two spin states: para-positronium (p-Ps, a singlet state with zero spin angular momentum), and ortho-positronium (o-Ps, a triplet state of unit spin angular momentum). In PALS experiments we are mostly interested in the o-Ps state, since its lifetime is environment dependent. In molecular materials, once formed, o-Ps localizes in the molecular free volumes, where it remains throughout its lifetime. As a consequence of the collisions of o-Ps with the "walls" of the hole in which it resides, the o-Ps' positron can annihilate with an electron with an opposite spin, other than its bound partner. The o-Ps lifetime therefore delivers information pertaining the mean free hole volume size in the material. Furthermore, PALS can probe the size of molecular free volumes at a wide range of temperatures, allowing the identification of important phase transitions which occur in molecular materials.

Acknowledgement: Dr M Roussanova,  
Physics Department, Bristol University, UK.

# PLS-System

## Benefits

- A fully tested and integrated “turn key” system. . . all you require is a positron source.
- A complete set of labeled cables and connectors.
- Two model 905-21 detector assemblies.
- Documentation of the test process and results.
- Warranted system time resolution.

## The PLS-SYSTEM Includes

- 2 model 905-21 Detector assemblies.
- 2 model 583B Constant Fraction Discriminators.
- 2 model 556 High Voltage Power Supplies.
- 1 model 414A Fast Coincidence.
- 1 model 567 Time-to-Amplitude Converter/Single Channel Analyzer.
- 1 model 928-MCB Multi-Channel Analyzer with MAESTRO Software.
- 1 model DB463 Delay Box.
- 1 model 4001A/4002D NIM Bin and Power Supply.
- 1 model 113 Preamplifier.
- 1 model 575A Spectroscopy Amplifier.
- 1 Personal Computer.
- 1 set of labeled cables and connectors.
- 1 procedure with documentation of the factory test.

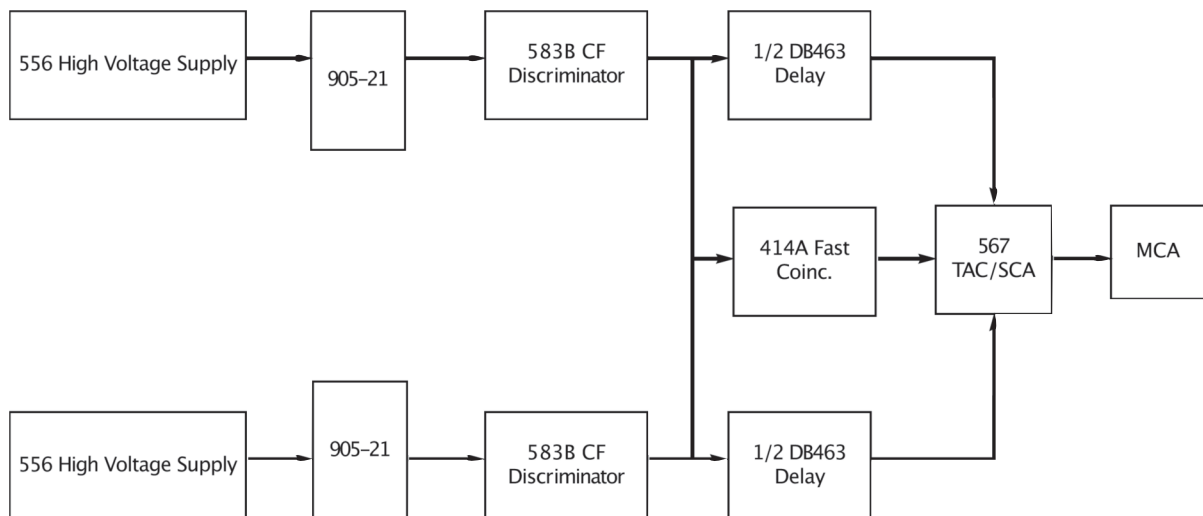

This system has a warranted time resolution of 200-Picoseconds (typically measures less than 180-Picoseconds) measured with a narrow energy window using a Co-60 source. (Sources are not included with this system.)

# PLS-System

## Ordering Information

Contact your local sales representative.

Specifications subject to change  
091322

**ORTEC**<sup>®</sup>

**[www.ortec-online.com](http://www.ortec-online.com)**

Tel. (865) 482-4411 • Fax (865) 483-0396 • [ortec.info@ametek.com](mailto:ortec.info@ametek.com)  
801 South Illinois Ave., Oak Ridge, TN 37830 U.S.A.  
For International Office Locations, Visit Our Website

**AMETEK**<sup>®</sup>  
ADVANCED MEASUREMENT  
TECHNOLOGY