

- Specifically designed to meet the demanding requirements of isotopic ratio software codes used in Safeguards and NDA.
- Excellent resolution is maintained over a wide range of count rates, enhancing measurement flexibility.
- Available in a full range of crystal diameters.
- Extensive range of cryostats with multi-orientation dewar options for applications requiring portability.
- Compatible with all existing Safeguards multichannel analyzers.

The precise measurement of isotopic ratios required in Safeguards and non-destructive assay (NDA) applications places a severe demand on the techniques of gamma-ray and x-ray spectroscopy. Figure 1 demonstrates the complexity of the 90–130 keV region of a typical Pu spectrum. The choice of energy region(s) for analysis depends specifically on the sample type and origin and the material matrix.

National laboratory software codes¹ written to obtain highly accurate isotopic ratios, must deal with these spectra to analyze low-energy and/or high-energy regions in which groups of peaks are located close together. Each code requires exceptional system resolution and stability in order to achieve accurate unfolding of these regions.

Recent safeguards development trends have led to a growing requirement of isotopic ratio determinations involving higher energy gamma-rays. Such needs spring from the need to measure attenuated samples, such as those found in waste assay and in certain homeland security applications. Software codes such as FRAM and MGAHI² can now determine Pu isotopic ratios from the higher energy regions of the spectrum. As a consequence, it is desirable to produce HPGe detectors that offer improved higher energy performance, while maintaining the excellent resolution characteristics required in such applications.

The ORTEC Safeguards series include both coaxial and planar geometry detectors, specifically designed to meet the demands of the applications software used for isotopic ratio determination, have been developed to strike an optimum balance between low-energy resolution and high-energy efficiency.

SGD series detectors are compatible with ALL conventional MCA types, although optimum performance will be obtained when used with the ORTEC Digital Signal Processing Spectrometers.

All SGD detectors feature the following:

- Choice of fixed, portable, and custom cryostats, including the latest MOD multi-orientation dewar option.
- Robust aluminum end-cap
- Streamline preamplifier assembly
- LN₂-Free option

The latest low-power resistive feedback preamplifier with “no ring” output, suitable for use with all existing types of MCA systems. Power consumption less than 25 mA at ±12 and ±24 V.

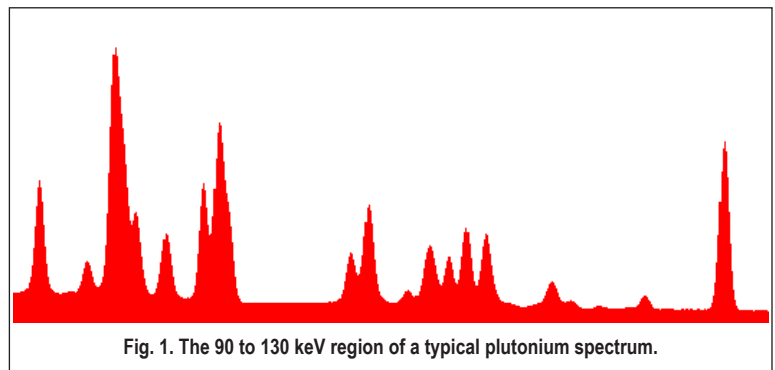

Fig. 1. The 90 to 130 keV region of a typical plutonium spectrum.

High-Performance Germanium Coaxial Detectors for Safeguards and Non-Destructive Assay Product Configuration Guide

Application Considerations

For samples in thick walled containers, or when significant matrix attenuation is present, it may be necessary to use a higher energy region of the spectrum to perform the analysis. In these cases, the SGD-GEM detectors, which are coaxial or semi-coaxial, have been developed to strike an optimum balance between low-energy resolution and high-energy efficiency.

The SGD-GEM-5050P4 is the “traditional” coaxial detector for use with FRAM³ in a wide variety of cases, including the measurement of UF6 cylinders.

The SGD-GEM-5030P4 has a semi-planar geometry and can be used as a more practical substitute for “telescope” detectors which have traditionally been used with the codes TRIFID and MGA in so-called “two-detector” mode. Recent improvements in crystal and preamplifier technologies have made it possible to gather both high- and low-energy spectra SIMULTANEOUSLY with a single SGD-GEM-5030P4 detector.

The SGD-GEM-6560P4 has been produced specifically to provide a large-area detector, which meets the resolution requirements of the FRAM code, and has good high-energy efficiency and a large detection area.

The Following Specifications are Provided for each SGD-GEM Detector

- Energy resolution at 1.33 MeV photons from ⁶⁰Co and 122 keV photons from ⁵⁷Co at optimum shaping time and 1 kcps.
- Energy resolution at 1.33 MeV photons from ⁶⁰Co and 122 keV photons from ⁵⁷Co at 2 μs shaping time and 1 kcps.
- Energy resolution at 1.33 MeV photons from ⁶⁰Co and 122 keV photons from ⁵⁷Co at 2 μs shaping time and 30 kcps.
- Peak shape ratio for the full width tenth maximum to the full width half maximum for ⁶⁰Co 1.33 MeV peak at optimum shaping time and 1 kcps.
- Peak shape ratio for the full width fiftieth maximum to the full width half maximum for ⁶⁰Co 1.33 MeV peak at optimum shaping time and 1 kcps.

Configuration Guidelines

PopTop or Streamline (non-PopTop) Configuration

The essence of a PopTop detector system is that the HPGe detector element cryostat, preamplifier, and high voltage filter are housed in a detector “capsule” which is then attached to an appropriate cryostat (Figure 2.)

In so called Streamline systems, the detector capsule is NOT demountable. Detector capsule and cryostat share the same vacuum. In configuration terms, this requires a cryostat or cryostat/dewar selection with the cryostat having a matching diameter to the capsule endcap. A cryostat must always be ordered with a Streamline capsule, because they are integral.

The actual PopTop capsule has its own vacuum. It can be mounted on any of the available cryostats or cryostat/dewar combinations.

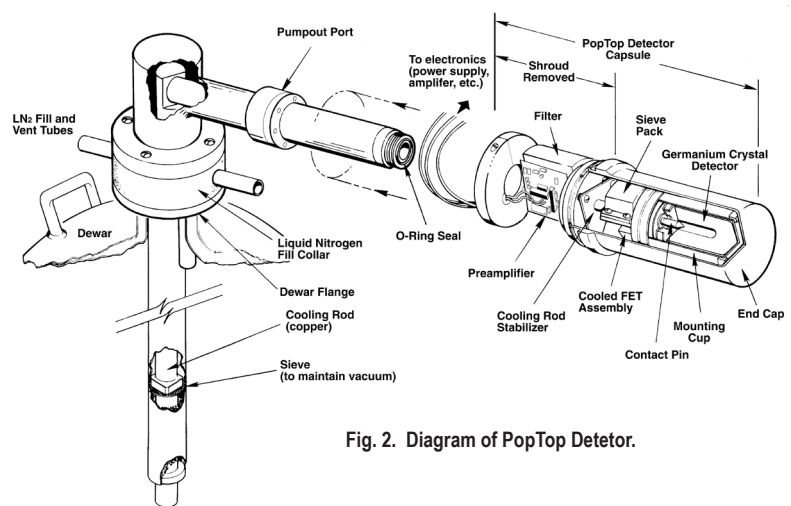

Fig. 2. Diagram of PopTop Detector.

¹ Specifically these codes are: FRAM from Los Alamos National Laboratory; MGA from Lawrence Livermore National Laboratory and TRIFID from Rocky Flats Plant.

² MGAHI is now included in the MGA-B32 suite of software available from ORTEC.

³ See for example LA-UR-98-2007 Los Alamos reprint “Test and Evaluation of FRAM Isotopic Analysis Code for Euratom Applications”, T.E. Sampson et al. Paper presented at the 1999 INMM, Phoenix, AZ.

Steps to Configure Your ORTEC HPGe Detector

1) Configure the Detector Model

- Capsule type (PopTop or Streamline)
- Ge Crystal dimensions and specifications
- Endcap and window
- Mount
- Preamplifier
- Cable Package

Preamplifier options are available.

2) Configure the Cryostat/Dewar Model

- Vertical Dipstick style (separate Dewar or Mobius Recycler)
- Horizontal Dipstick style (separate Dewar or Mobius Recycler)
- Portable with all-position or multi-position cryostat/dewar models
- Downlooking designed to be oriented with the detector pointing down
- Sidelooking designed to be oriented with the detector horizontal at the bottom of the dewar
- “J” configurations designed with the detector attached near the bottom of the dewar and a right angle bend in the cryostat orienting the detector to look up.

A cryostat and dewar or other cooling device are required for operation.

If a PopTop detector has been selected, you can choose a PopTop style cryostat or cryostat/dewar combination.

If a Streamline detector has been selected, you must choose a cryostat or cryostat/dewar model for the detector to be mounted on and vacuum sealed. The cryostat or cryostat/dewar combination diameter must match the endcap diameter of the selected detector.

Detector Options

SMART-1 Option (-SMP)

The SMART-1 option monitors and reports on vital system functions, and can save authentication codes and report the code at a later time. It has the high voltage included, so none of the instruments require an external high-voltage power supply.

The SMART-1 is housed in a rugged ABS molded plastic enclosure and is permanently attached to the detector endcap via a molded-strain-relieved sealed cable. This eliminates the possibility that the detector will suffer severe damage from moisture leaking into high-voltage connectors. The SMART-1 can be positioned in any convenient place and does not interfere with shielding or other mounting hardware.

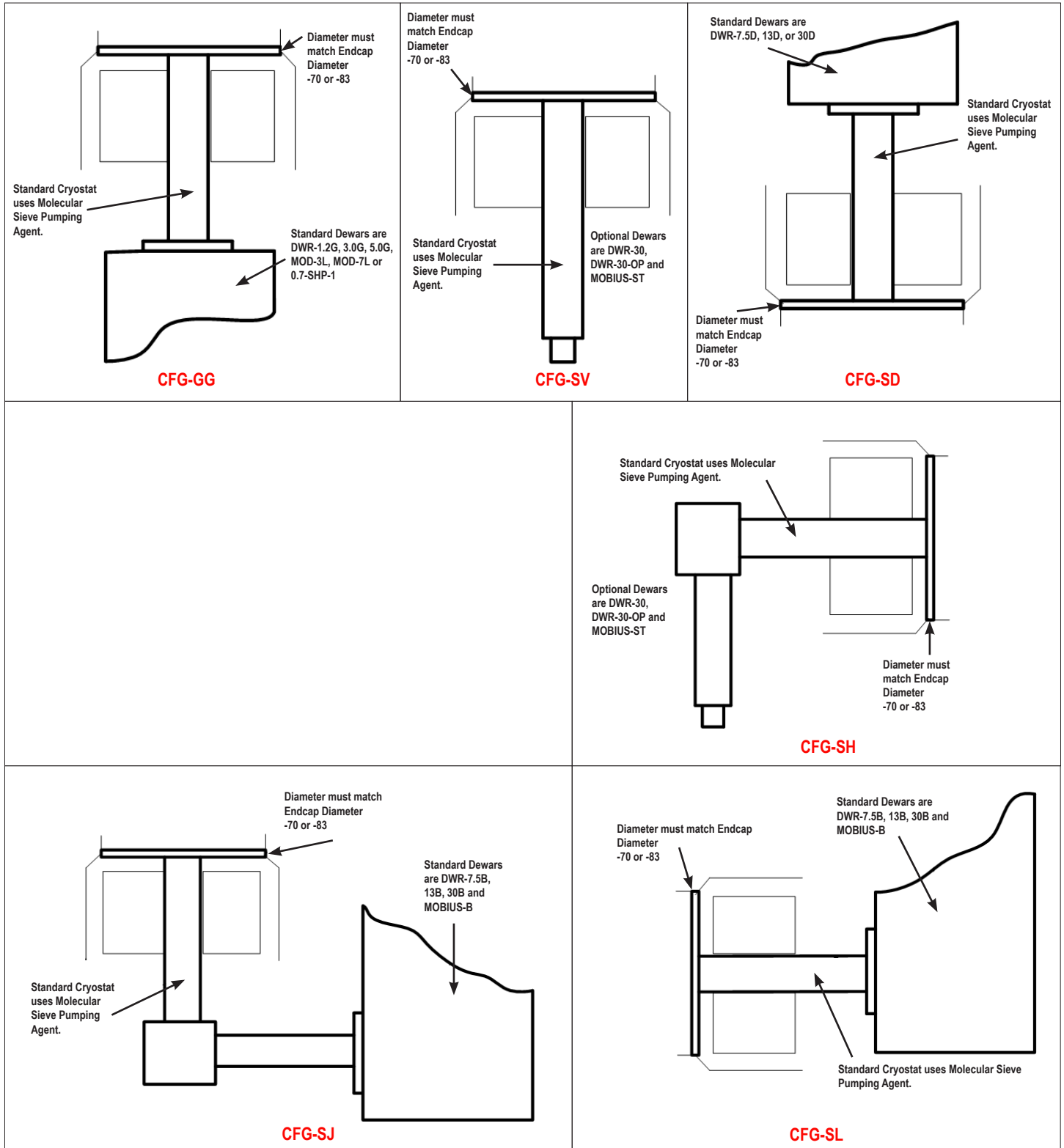

Fig. 4. SMART-1 Detector Interface Module.

High-Performance Germanium Coaxial Detectors for Safeguards and Non-Destructive Assay Product Configuration Guide

Streamline Cryostat and Cryostat/Dewar Assemblies

Streamline systems (detector capsule and cryostat) share the same vacuum, requiring a cryostat or cryostat/dewar selection with the cryostat having a matching diameter to the capsule endcap.



High-Performance Germanium Coaxial Detectors for Safeguards and Non-Destructive Assay Product Configuration Guide

PopTop and Streamline Dimensional Data

Streamline systems (detector capsule and cryostat or ICS) share the same vacuum. A cryostat or ICS must be ordered with a Streamline capsule. The cryostat or cryostat/dewar selection must have a matching diameter to the capsule endcap.

The PopTop capsule features an internal vacuum arrangement. It can be mounted on any of the available PopTop cryostats, cryostat/dewar combinations, or ICS-P4 mechanical cooling systems.

The cryostat and dewar drawings that follow are to be used in conjunction with the accompanying tables of dimensions.

**Note: Cryostat/Dewar drawings are NOT to scale, see tables that follow for complete dimensions.
Dimensions are for reference only and subject to change, if dimensional constraints are critical, contact the factory.**

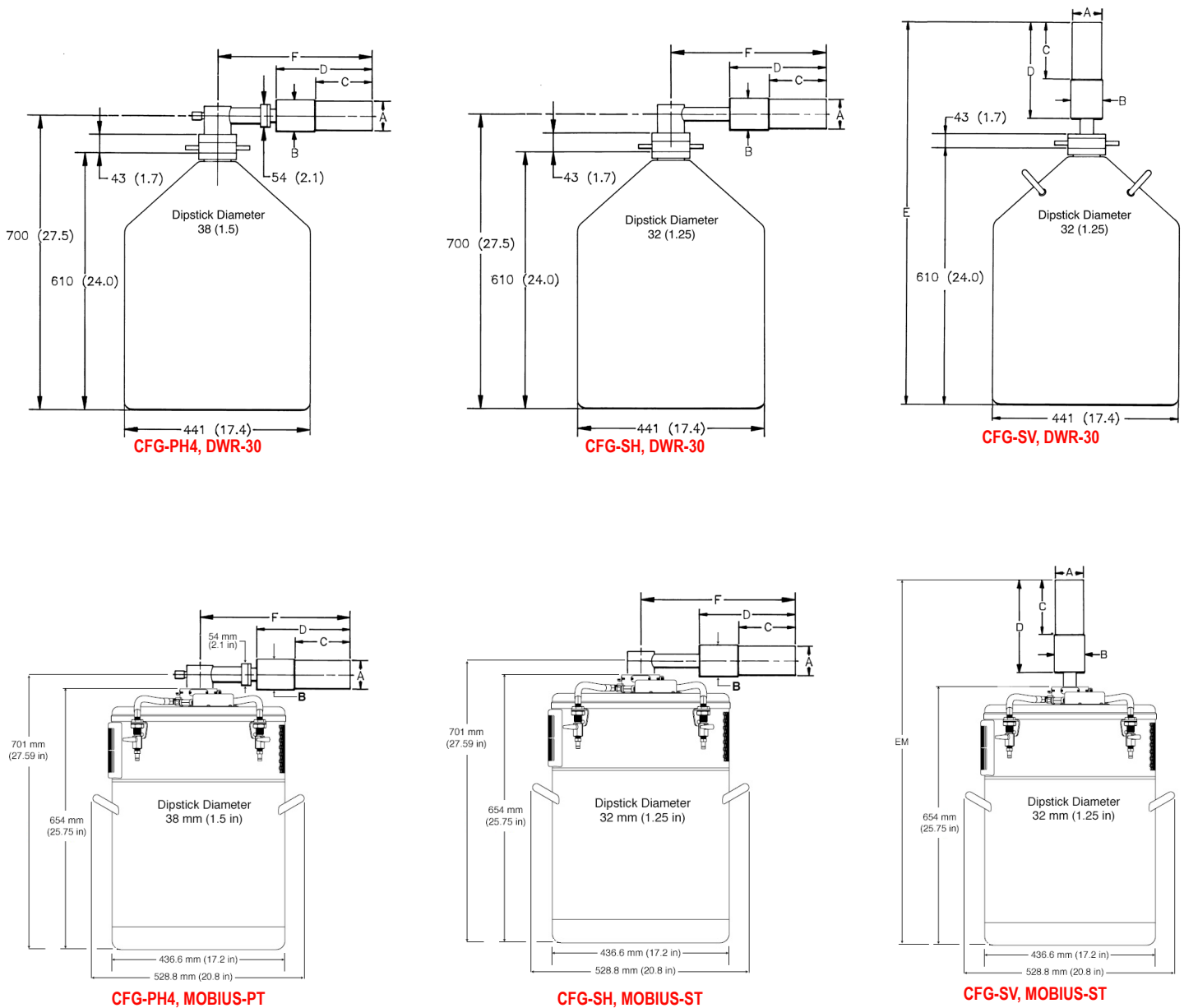

High-Performance Germanium Coaxial Detectors for Safeguards and Non-Destructive Assay Product Configuration Guide

**Note: Cryostat/Dewar drawings are NOT to scale, see tables that follow for complete dimensions.
Dimensions are for reference only and subject to change, if dimensional constraints are critical, contact the factory.**

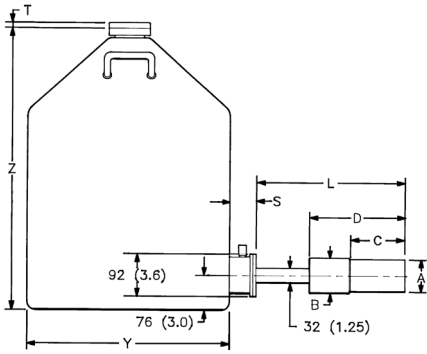

**CFG-PS4-30 (or -13 or -7.5) or
CFG-SL, DWR-30B (or -13B or -7.5B)**

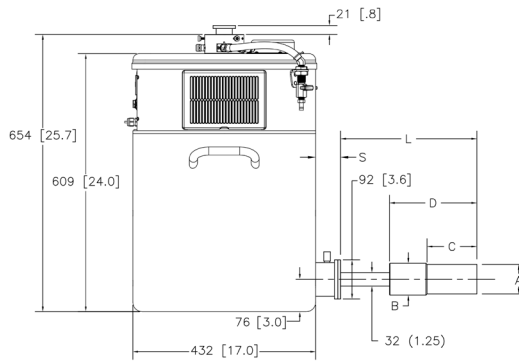

CFG-PS4-MOBIUS-B or CFG-SL, MOBIUS-B

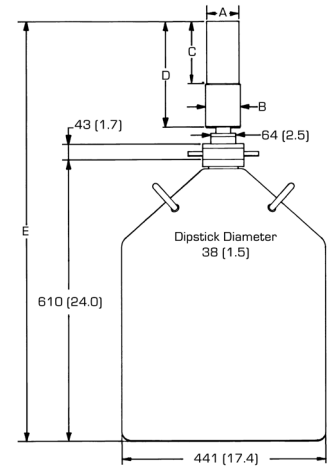

CFG-PV4, DWR-30

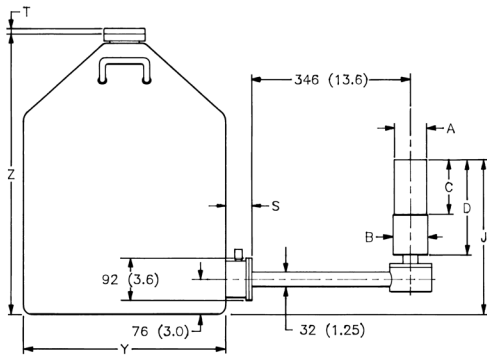

CFG-SJ, DWR-30B (or -13B or -7.5B)

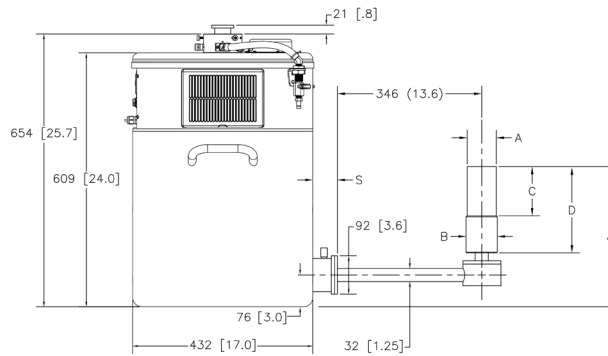

CFG-SJ, MOBIUS-B

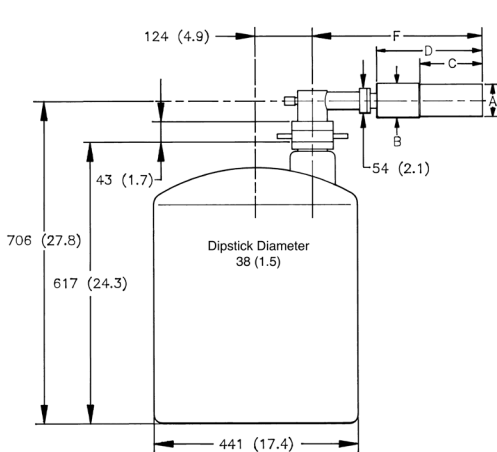

CFG-PH4, DWR-30-OP

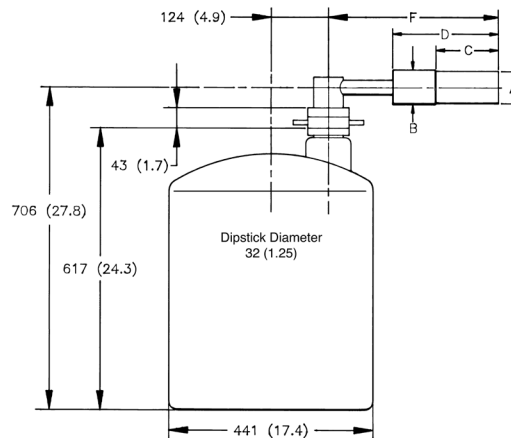

CFG-SH, DWR-30-OP

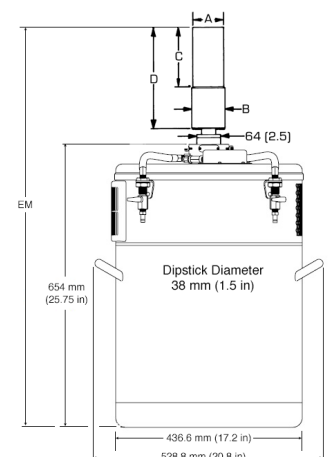

CFG-PV4, MOBIUS-PT

High-Performance Germanium Coaxial Detectors for Safeguards and Non-Destructive Assay Product Configuration Guide

**Note: Cryostat/Dewar drawings are NOT to scale, see tables that follow for complete dimensions.
Dimensions are for reference only and subject to change, if dimensional constraints are critical, contact the factory.**

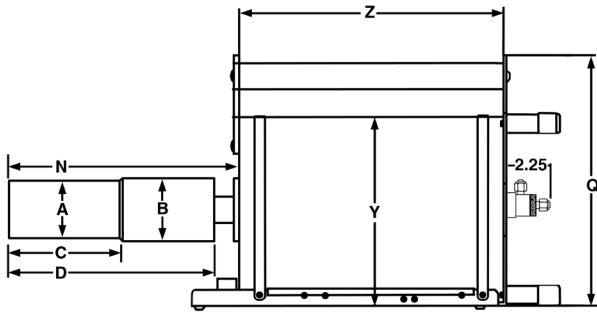

**CFG-PG4-1.2 (or -3 or -5) or
CFG-GG, DWR-1.2G (or -3.0G, -5.0G)**

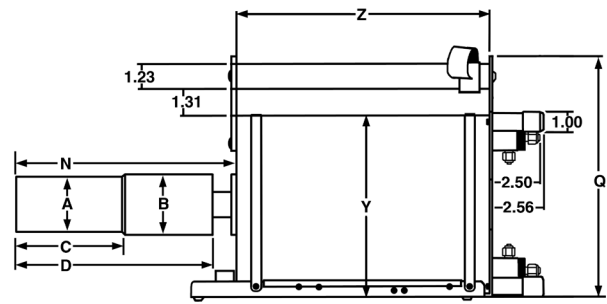

**CFG-PMOD4-3 (or -7) or
CFG-GG, DWR-MOD3L (or -MOD7L)**

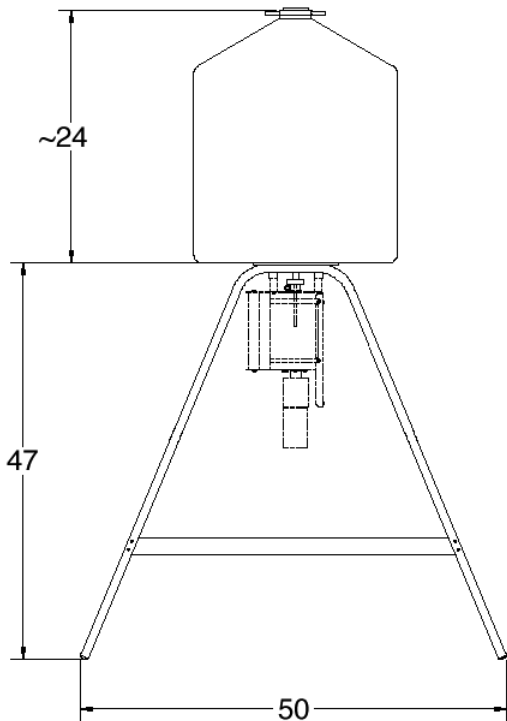

DWR-S/F

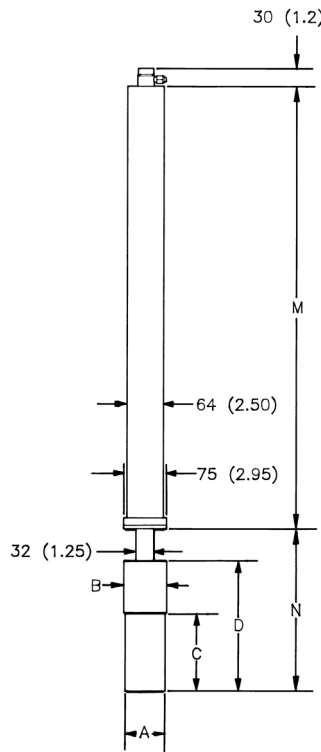

**CFG-PSHP4 or
CFG-GG, DWR-0.7-SHP-1**

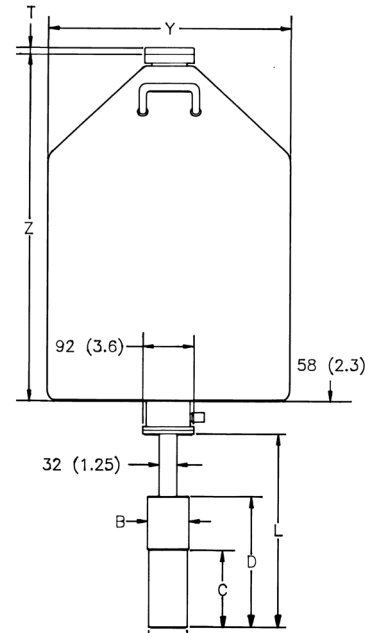

**CFG-PD4-30 (or -13 or -7.5) or
CFG-SD, DWR-30D (or -13D or -7.5D)**

High-Performance Germanium Coaxial Detectors for Safeguards and Non-Destructive Assay Product Configuration Guide

Streamline SGD-GEM Detector Dimensions

- Dimensions are for reference only and subject to change.
- If dimensional constraints are critical, contact the factory.

Endcap Model (dia. mm)			-70	-83
Dim.	Unit	Tol.		
A	mm (in)	0.3 (0.01)	70 (2.75)	83 (3.25)
B	mm (in)	0.3 (0.01)	75 (2.95)	88 (3.45)
C	mm (in)	5 (0.2)	134 (5.3)	134 (5.3)
D	mm (in)	8 (0.3)	246 (9.7)	259 (10.2)
E	mm (in)	18 (0.7)	916 (36.1)	932 (36.7)
EM	mm (in)	19 (0.75)	917 (36.1)	933 (36.7)
F	mm (in)	10 (0.4)	368 (14.5)	381 (15.0)
H	mm (in)	18 (0.7)	351 (13.8)	364 (14.3)
HB	mm (in)	0.3 (0.1)	73 (2.9)	85 (3.4)
HC	mm (in)	5 (0.2)	134 (5.3)	135 (5.3)
HD	mm (in)	10 (0.4)	162 (6.4)	175 (6.9)
J	mm (in)	10 (0.4)	380 (15)	393 (15.5)
L	mm (in)	10 (0.4)	338 (13.3)	351 (13.8)
M	mm (in)	8 (0.3)	516 (20.3)	X X
N	mm (in)	10 (0.4)	278 (11)	292 (11.5)

PopTop SGD-GEM Detector Dimensions

- Dimensions are for reference only and subject to change.
- If dimensional constraints are critical, contact the factory.

Endcap Model (dia. mm)			-70	-83
Dim.	Unit	Tol.		
A	mm (in)	0.3 (0.01)	70 (2.75)	83 (3.25)
B	mm (in)	0.3 (0.01)	75 (2.95)	88 (3.45)
C	mm (in)	5 (0.2)	134 (5.3)	168 (6.6)
D	mm (in)	8 (0.3)	250 (9.8)	282 (11.2)
E	mm (in)	18 (0.7)	947 (37.3)	982 (38.6)
EM	mm (in)	19 (0.75)	948 (37.3)	983 (38.7)
F	mm (in)	10 (0.4)	396 (15.6)	429 (16.9)
L	mm (in)	10 (0.4)	338 (13.3)	371 (14.6)
M	mm (in)	8 (0.3)	790 (31.1)	X X
N	mm (in)	10 (0.4)	278 (11)	312 (12.3)

High-Performance Germanium Coaxial Detectors for Safeguards and Non-Destructive Assay Product Configuration Guide

Gamma Gage and Side-Looking Dewar Dimensions

- Dimensions are for reference only and subject to change.
- If dimensional constraints are critical, contact the factory.

			Cryostat/Dewar or Dewar Type							
			CFG-PG4 and DWR-x.xG			CFG-PMOD4 and DWR-MOD-xL		CFG-PS4, CFG-PD4, DWR-xxB and DWR-xxD		
			VOLUME			VOLUME		VOLUME		
Dim.	Unit	Tol. ±	1.2L	3L	5L	3L	7L	7.5L	13L	30L
Q	mm (in)	13 (0.5)	229 (9.0)	302 (11.9)	302 (11.9)	229 (9.0)	302 (11.9)	X X	X X	X X
R	mm (in)	10 (0.4)	X X	X X	X X	X X	X X	174 (6.9)	174 (6.9)	155 (6.1)
S	mm (in)	7.6 (0.3)	X X	X X	X X	X X	X X	77 (3.0)	77 (3.0)	60 (2.3)
T	mm (in)	5 (0.2)	X X	X X	X X	X X	X X	10 (0.4)	10 (0.4)	13 (0.5)
Y	mm (in)	13 (0.5)	157 (6.2)	229 (9.0)	229 (9.0)	157 (6.2)	229 (9.0)	224 (8.8)	307 (12.1)	442 (17.4)
Z	mm (in)	5 (0.2)	229 (9.0)	267 (10.5)	419 (16.5)	292 (11.5)	320 (12.6)	452 (17.8)	429 (16.9)	610 (24.0)

Defining the Detector Model

- See ordering information for option compatibility.

Base Model (example)	PopTop or Streamline	High Voltage Option (if required)
SGD-GEM3165	P4 (PopTop) (Streamline)	-SMP

Example Model Numbers

Streamline Configuration

SGD-GEM-3615	3% efficiency SGD-GEM detector with 70-mm diameter endcap.
CFG-GG-70	Portable Gamma Gage cryostat with matching 70-mm diameter flange.
DWR-1.2G	1.2 liter all-position dewar for Gamma Gage cryostat.
SGD-GEM-5050-SMP	20% efficiency SGD-GEM detector with 70-mm diameter endcap and SMART-1 preamplifier and high voltage supply.
CFG-SD-70	Down-looking cryostat with matching 76-mm diameter flange.
DWR-7.5D	7.5 liter down-looking dewar.

PopTop Configuration

SGD-GEM-3615P4	3% efficiency SGD-GEM detector with 70-mm diameter endcap.
CFG-PG4-1.2	Portable Gamma Gage cryostat with 1.2 liter all-position dewar.
SGD-GEM-5050P4-SMP	20% efficiency GEM detector with 70-mm diameter endcap and SMART-1 preamplifier and high voltage supply.
CFG-PD4-7.5	Downlooking cryostat with 7.5 liter dewar.

High-Performance Germanium Coaxial Detectors for Safeguards and Non-Destructive Assay Product Configuration Guide

Ordering Information and Warranted Specifications

- For Streamline, remove the "P4" from the model number.
- If dimensional considerations are critical, contact factory.
- Cryostat and dewar or other cooling device are not included with detector and are required for operation.
- A cryostat must be ordered with a Streamline detector.
- Monte Carlo drawing included.

Model No.	Active Diameter mm Nominal	Thickness mm Minimum	Relative Efficiency % Nominal	Resolution		Peak Shape		Resolution, Short Shaping Time				Endcap Diameter mm Nominal
				@1.33 MeV keV FWHM @1 kcps Maximum	@122 keV keV FWHM @1 kcps Maximum	FW.1M/ FWHM @1kcps Maximum	FW.02M/ FWHM @1kcps Maximum	@1.33 MeV keV FWHM @1 kcps Maximum	@1.33 MeV keV FWHM @30 kcps Maximum	@122 keV keV FWHM @1 kcps Maximum	@122 keV keV FWHM @30 kcps Maximum	
SGD-GEM-3615P4	36	15	2	1.7	0.61	1.9	2.6	1.8	2.0	0.65	0.67	70
SGD-GEM-5030P4	50	30	13	1.7	0.65	1.9	2.6	1.9	2.1	0.69	0.75	70
SGD-GEM-5050P4	50	50	20	1.8	0.75	1.9	2.6	2.0	2.1	0.88	0.89	70
SGD-GEM-6560P4	65	60	50	1.8	0.80	1.9	2.6	2.1	2.2	0.94	0.96	83

SGD-GEM Detector Options

- Append suffix to base model number.

Suffix	Description
--------	-------------

-SMP	SMART-1 detector option for positive bias detector, add "-SMP" to the model number.
------	---

SGD-GEM PopTop Cryostats and Dewars

Model No.	Description
CFG-PD4-7.5	Down-looking Cryostat with 7.5-liter Dewar
CFG-PD4-13	Down-looking Cryostat with 13-liter Dewar
CFG-PD4-30	Down-looking Cryostat with 30-liter Dewar
CFG-PG4-1.2	Gamma Gage Cryostat with 1.2-liter Dewar (for 83 mm or smaller endcaps)
CFG-PG4-3	Gamma Gage Cryostat with 3-liter Dewar
CFG-PG4-5	Gamma Gage Cryostat with 5-liter Dewar
CFG-PH4	Horizontal Cryostat (Dipstick type). Choose DWR-30, DWR-30-OP, MOBIUS-PT or MOBIUS-PT-DET.
CFG-PMOD4-3	Gamma Gage Cryostat with 3-liter Multi-Orientation Dewar
CFG-PMOD4-7	Gamma Gage Cryostat with 7-liter Multi-Orientation Dewar
CFG-PS4-7.5	Side-Looking Cryostat with 7.5-liter Dewar
CFG-PS4-13	Side-Looking Cryostat with 13-liter Dewar
CFG-PS4-30	Side-Looking Cryostat with 30-liter Dewar
CFG-PS4-MOBIUS-B	Side-Looking Cryostat with Möbius Recycler 28-liter Dewar
CFG-PS4-MOBIUS-B-DET	Side-Looking Cryostat with Möbius Recycler 28-liter Dewar for purchase in combination with any PopTop detector.
CFG-PSHP4	Down-Looking Shallow-Hole Probe with 0.7-liter Dewar
CFG-PV4	Vertical Cryostat (Dipstick type). Choose DWR-30, DWR-30-OP, MOBIUS-PT or MOBIUS-PT-DET.
MOBIUS-PT	Möbius Recycler.
MOBIUS-PT-DET	Möbius Recycler Dewar for purchase in combination with any PopTop detector and vertical or horizontal dipstick cryostat.
DWR-30	30-liter Dewar. Includes collar for 1.5" diameter cryostat.
DWR-30-OP	30-liter Offset-Port Dewar. Includes collar for 1.5" diameter cryostat.
DWR-S/F	Storage Fill Dewar for CFG-PG4-X

High-Performance Germanium Coaxial Detectors for Safeguards and Non-Destructive Assay Product Configuration Guide

SGD-GEM Streamline Cryostats

- May only be purchased with a detector.
- Dewar required. Select dewar from GEM Streamline Dewars.
- Horizontal and Vertical Cryostats include CFG-ADAPTOR to increase cryostat diameter from 1.25 inch to 1.5 inch for use with DWR-30 and DWR-30-OP.
- Append matching Detector Endcap Size designation to cryostat model: -70 or -83 [e.g., CFG-SJ-70 for SGD-GEM-3615]

Model No.	Description
CFG-GG	Gamma Gage Cryostat
CFG-SD	Down-Looking Cryostat
CFG-SH	Horizontal Cryostat (Dipstick type).
CFG-SJ	J-type Cryostat
CFG-SL	Side-Looking Cryostat
CFG-SV	Vertical Cryostat (Dipstick type).

SGD-GEM Streamline Dewars

For Cryostat	Choose	Description
CFG-GG	DWR-1.2G	1.2-liter All-Orientation Dewar
	DWR-3.0G	3.0-liter All-Orientation Dewar
	DWR-5.0G	5.0-liter All-Orientation Dewar
	DWR-MOD-3L	3-liter Multi-Orientation Dewar
	DWR-MOD-7L	7-liter Multi-Orientation Dewar
	DWR-0.7-SHP-G	0.7-liter Shallow-Hole Probe Dewar
	DWR-S/F	Storage/Fill Dewar for DWR-XG
CFG-SJ, SL	DWR-7.5B	7.5-liter Side-Looking Dewar
	DWR-13B	13-liter Side-Looking Dewar
	DWR-30B	30-liter Side-Looking Dewar
	MOBIUS-B	Möbius Recycler Side-Looking Dewar
CFG-SD	DWR-7.5D	7.5-liter Down-Looking Dewar
	DWR-13D	13-liter Down-Looking Dewar
	DWR-30D	30-liter Down-Looking Dewar
CFG-SV, SH	DWR-30	30-liter Dewar. Includes collar for 1.5" diameter cryostat.
	DWR-30-OP	30-liter Offset-Port Dewar. Includes collar for 1.5" diameter cryostat.
	MOBIUS-ST	Möbius Recycler Dewar for purchase stand alone
	MOBIUS-ST-DET	Möbius Recycler Dewar for purchase in combination with Detector